



**MATERIAL  
COMPLEMENTARI**

**MÚSICA**



---

TERCER DE PRIMÀRIA

Ceip Carraixet



# UNITAT 1 (3)

A

kua - li - tum ba - ri tu - ka tum - bi tum - bi  
kua - li - tum ba - ri tu - ka tum - bi tum  
tum kua - li - tum kua - li - tum tum ba - ri  
tum kua - li - tum kua - li - tum tum - bi

## 1 Solfegem i cantem «Porta oberta».

Por - ta o - ber - ta, por - ta co - ber - ta,  
por - ta tan - cà, bo - na ma - çà!

## 2 Respon les preguntes sobre la cançó.

- Quin és el compàs? .....
- Quants compassos té? .....
- Quina és la nota més greu? .....
- I la més aguda? .....

## 3 Repassem i dibuixem la clau de sol.

Dibuixa la clau de sol i les notes en el pentagrama.

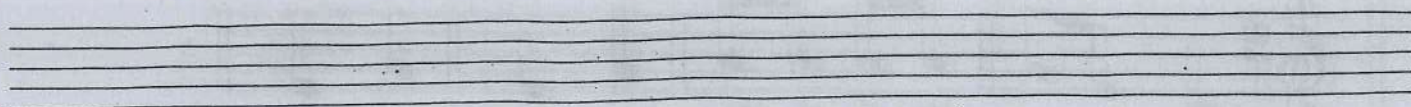

sol mi do fa la sol mi fa do si

Recorda com es diuen les notes.



Escriu el nom de les notes.



Relaciona.

1. A mi-do-fa-la-sol-la-sol-fa-mi-sol

2. B sol-fa-mi-do-mi-sol-la-sol-fa-sol

3. C do-mi-fa-sol-la-sol-fa-mi-do

Solfegem i cantem «Així fan, fan, fan».

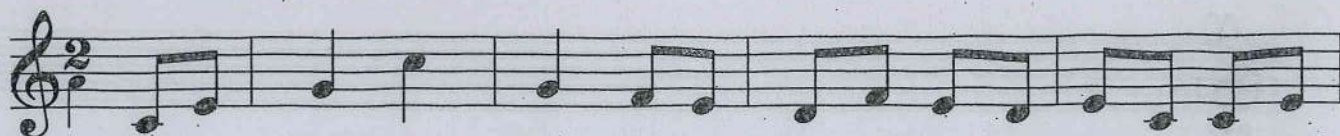

Ai - xí fan, fan, fan, els pe - tits bo - nics ti - te - lles, ai - xí

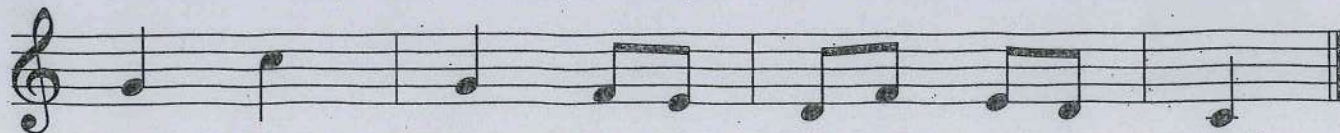

fan, fan, fan, tres vol - te - tes i se'n van.

**2** Escrivim 

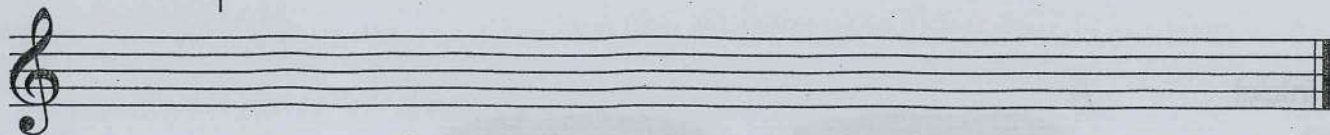

d m s d' s d' l s m r d d'

**3** Encercllem la nota que sona.

Four diagrams showing a central note 'sol' with arrows pointing to other notes: do', sol, mi, do. The notes to be circled are: do', sol, mi, do; do', sol, mi, do; sol, sol, mi, do; sol, sol, mi, do.

**1** Solfegem i cantem «Serra, serrador».

- \* Quin és el compàs de la cançó? .....
- \* Comença amb anacrusi? .....
- \* Quina és la nota més greu? .....
- \* I la més aguda? .....
- \* Quants compassos té la cançó? .....

Acompanyem la cançó amb aquest *ostinato*.

*palmes* 

Generalment, el **si** porta el pal cap avall.

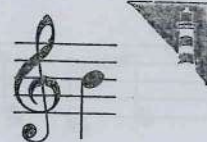

**2** Escrivim 

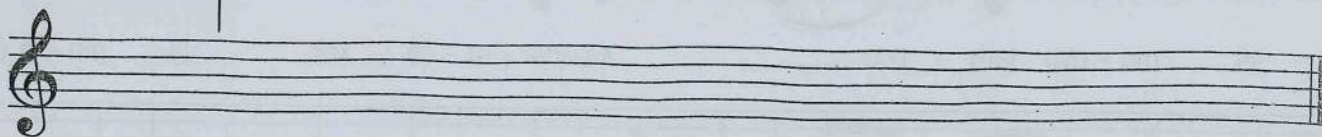

d m d' f s si d' l f d' si d'

# La dansa de la creu

posició inicial

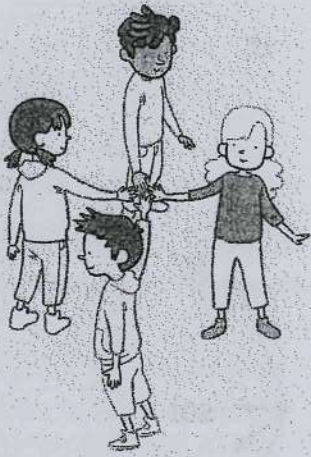

En cercle, formant un molinet.

A

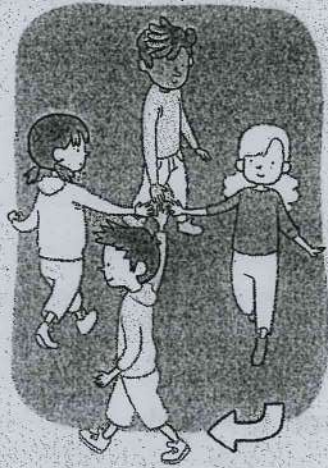

4 passos en cercle i canvi de mà.

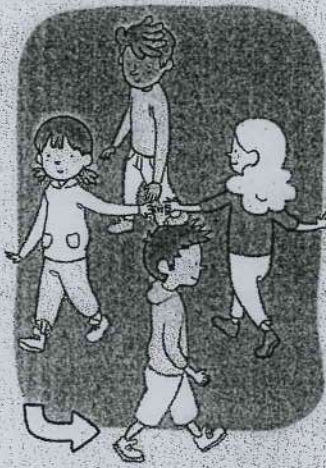

4 passos en l'altre sentit.

2 vegades

B



3 salts arrere.



3 salts avant.

4 vegades

Xacarracaxac

Xa - car - ra - ca - xac, no em to - ques la pin - ta: Xa - car - ra - c

xac, el mo - nyo tam - poc. Xa - car - ra - ca - xac, la pin - ta és d

pla - ta. Xa - car - ra - ca - xac, i el mo - nyo és d'or.

# 1 Solfegem i cantem «Totes les monges».

To - tes les mon - ges de bon de ma - tí  
s'al - cen i re - guen el seu jar - dí.

Jo també regue  
el meu bancalet,  
faves i pèsols i ravenets.

Ai!, ravenet,  
com t'has quedat,  
sense fulletes i el cap pelat!

## 2 Reconeixem.

1  
2  
3  
4

--	--	--	--	--

## 5

### 2 Escriu el nom de les notes.

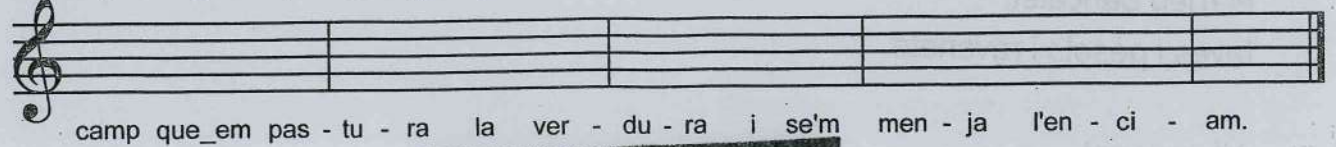
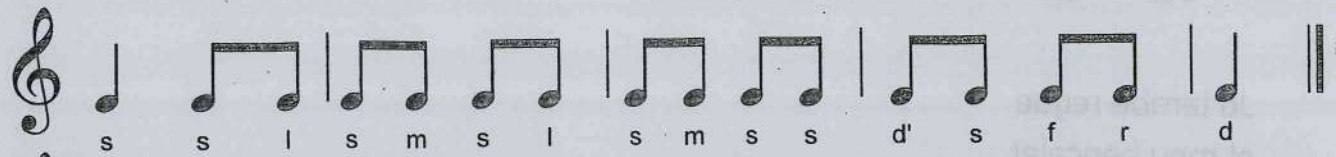
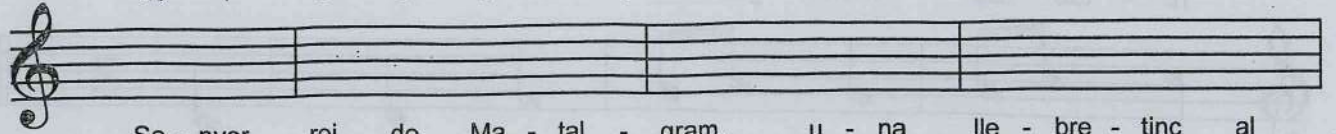
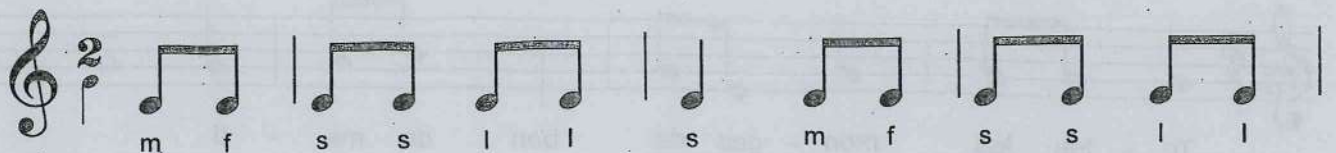

## GREENSLEAVES

A

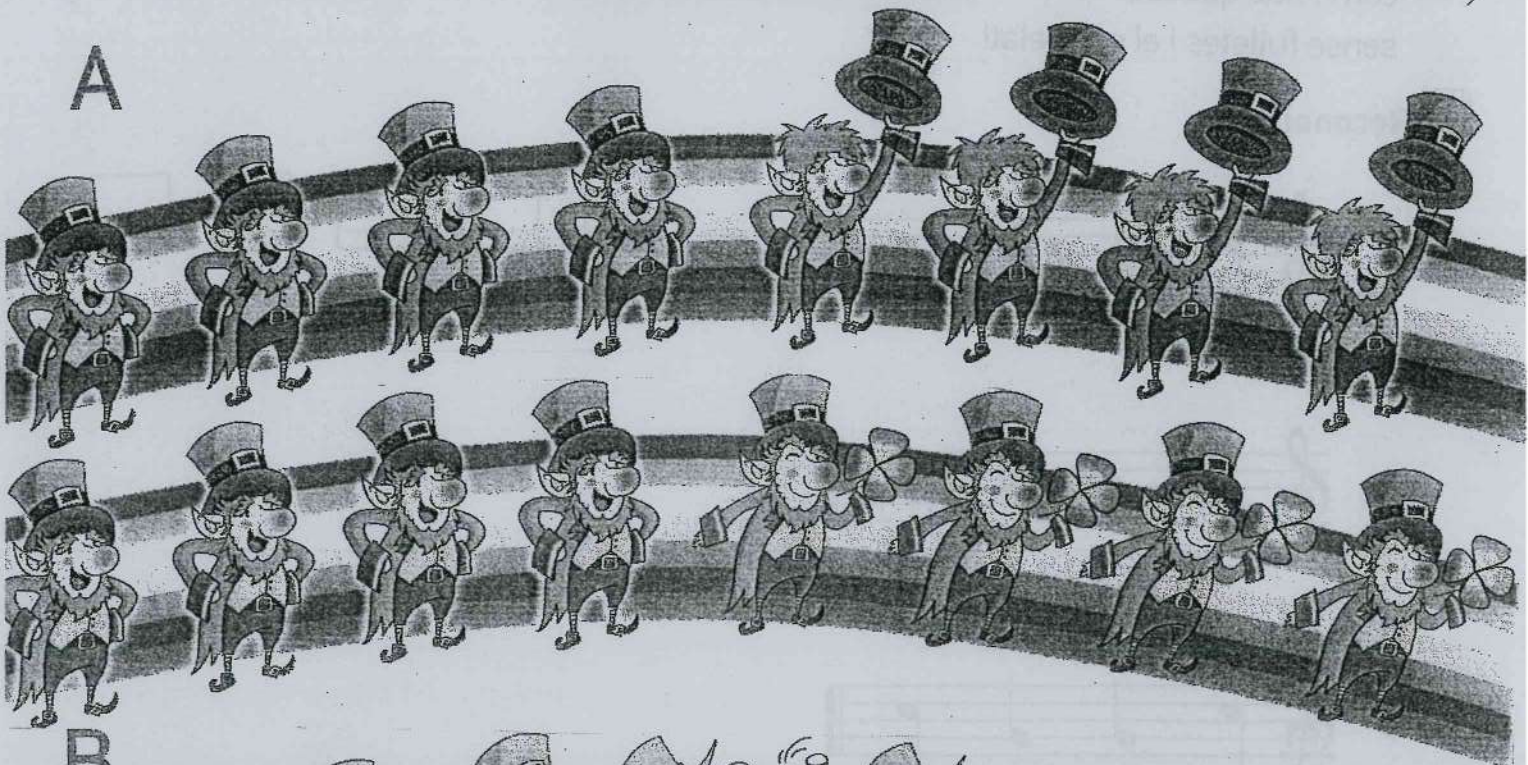

B



Forma: A-A-B-A-B-A



Recorda.

Figura	Nom	Síl·laba rítmica	Durada
	Blanca amb puntet	Taaa	3 ♥
	Blanca	Taa	2 ♥
	Negra	Ta	1 ♥
	Dues corxeres	Ti-Ti	1 ♥
	Silenci de negra	s	1 ♥
	Silenci de blanca	ss	2 ♥

Compta les pulsacions que hi ha en cada camí.

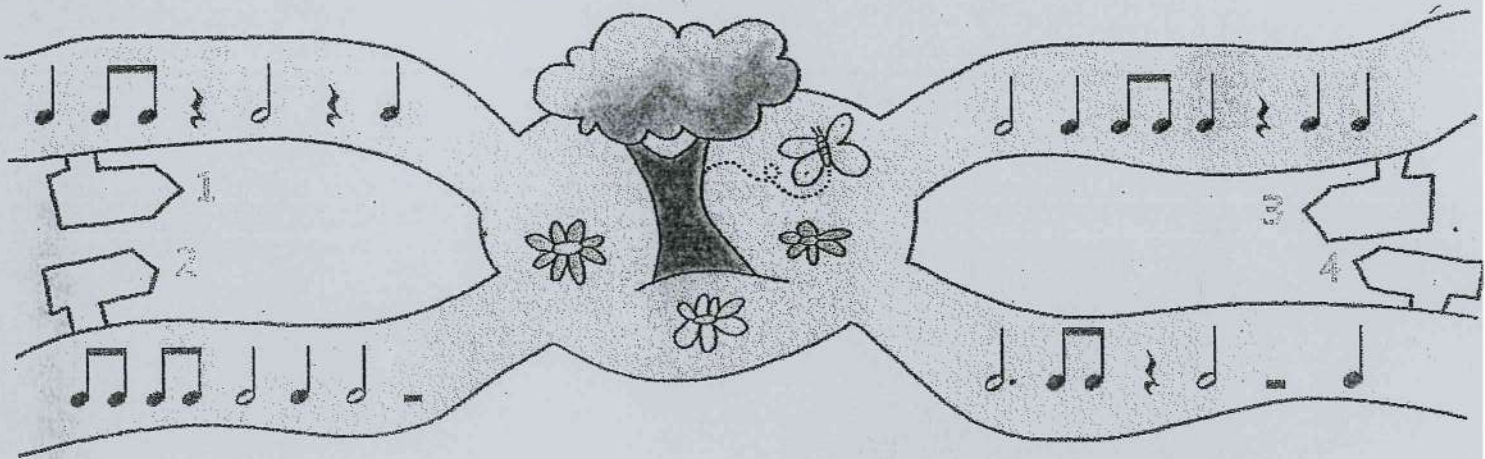

Quin camí és el més llarg? \_\_\_\_\_

Quin camí és el més curt? \_\_\_\_\_

Pinta de blau els ritmes que tenen dues pulsacions i de roig els ritmes que en tenen tres



Figura	Nom	Durada

# CLASSIFICACIÓ DELS INSTRUMENTS

Podem classificar els instruments segons el que vibra a l'hora de produir el so.

Instruments	Què vibra?
cordòfons	les cordes
aeròfons	l'aire
membranòfons	una membrana tensada sobre un ressonador
idiòfons	tot el cos de l'instrument
electròfons	la vibració és elèctrica

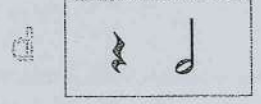
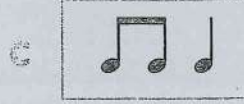
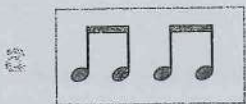
## CORDÒFONS

corda fregada

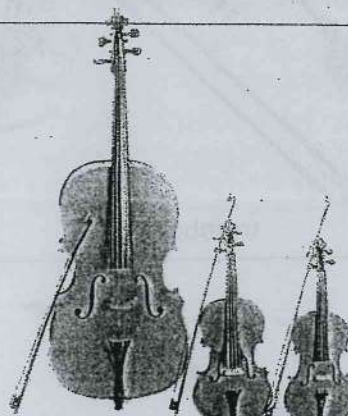
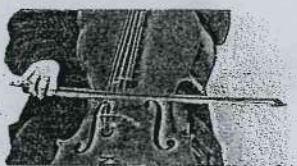

violoncel    viola    violí

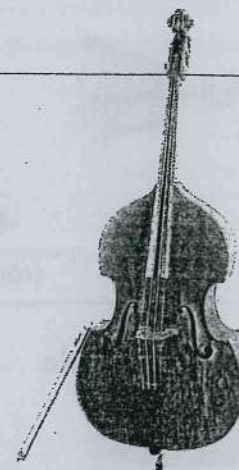

contrabaix

corda pinçada



guitarra



arpa



clavecí

corda percutida

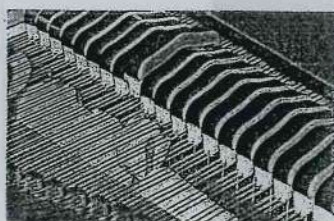

piano

## AERÒFONS

de bisell

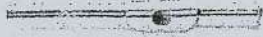

flauta travessera



flauta de bec

d'embocadura

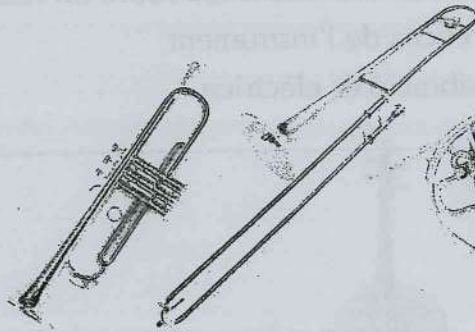

trompeta

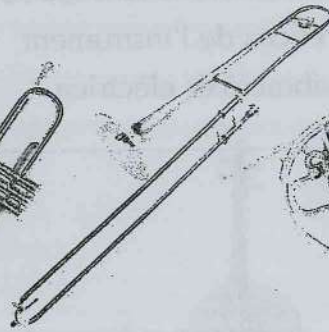

trombó

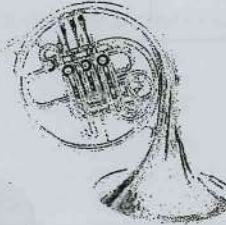

trompa

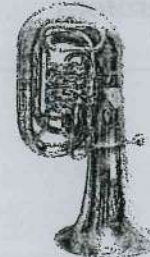

tuba



fiscorn

de llengüeta simple



clarinet



saxo

de llengüeta doble



oboé



corn anglés



fagot



dolçaina

combinació de sistemes

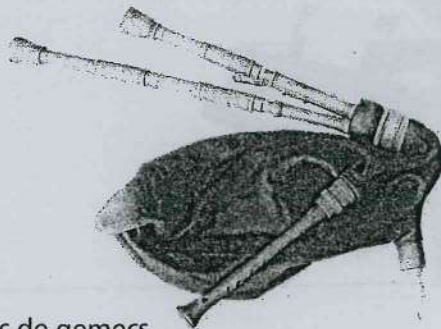

sac de gemecs

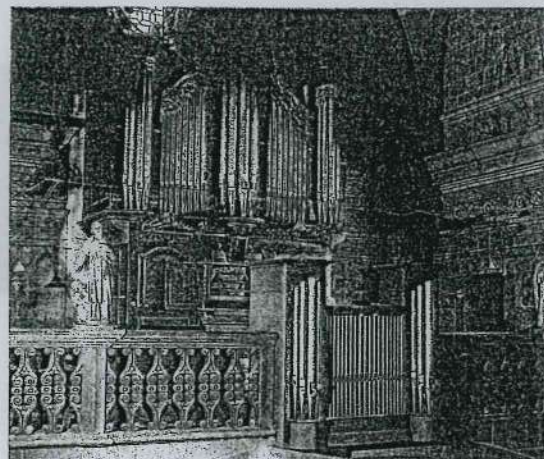

orgue

## MEMBRANÒFONS

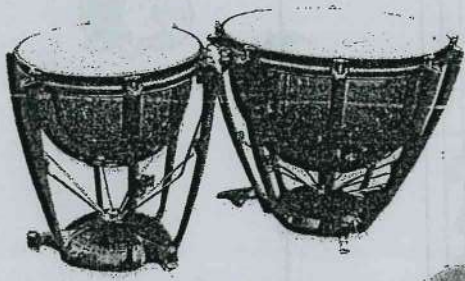

timbales

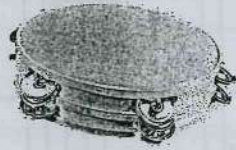

pandereta

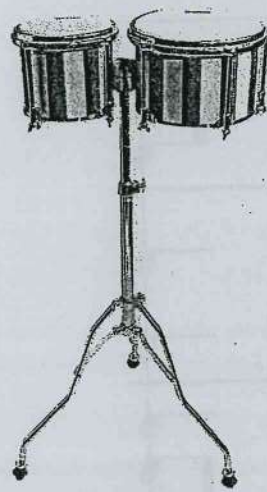

bongos

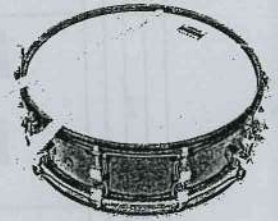

caixa

## IDIÒFONS

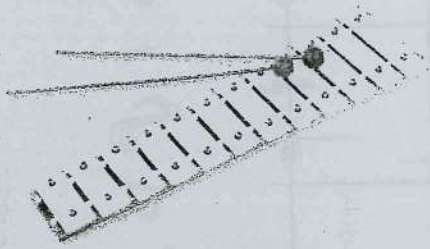

metal·lòfon



caixa xinesa

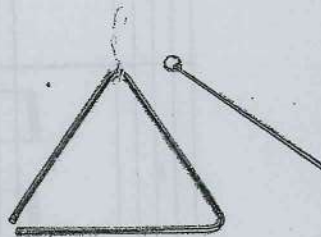

triangle



esquellot

## ELECTRÒFONS

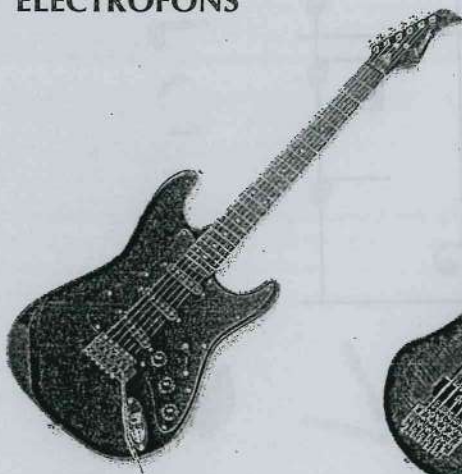

guitarra elèctrica



baix elèctric



sintetitzador

ACTIVITAT 2



Un, dos, un, dos, el com - pàs de dos.

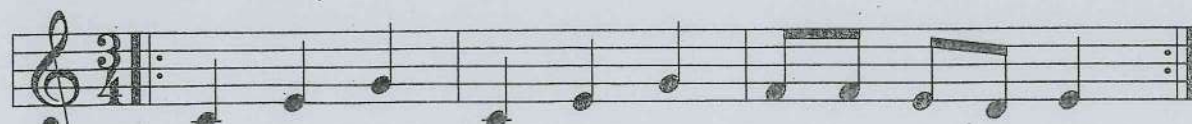

Un, dos, tres, un, dos, tres, el com - pàs de tres.

### El compàs



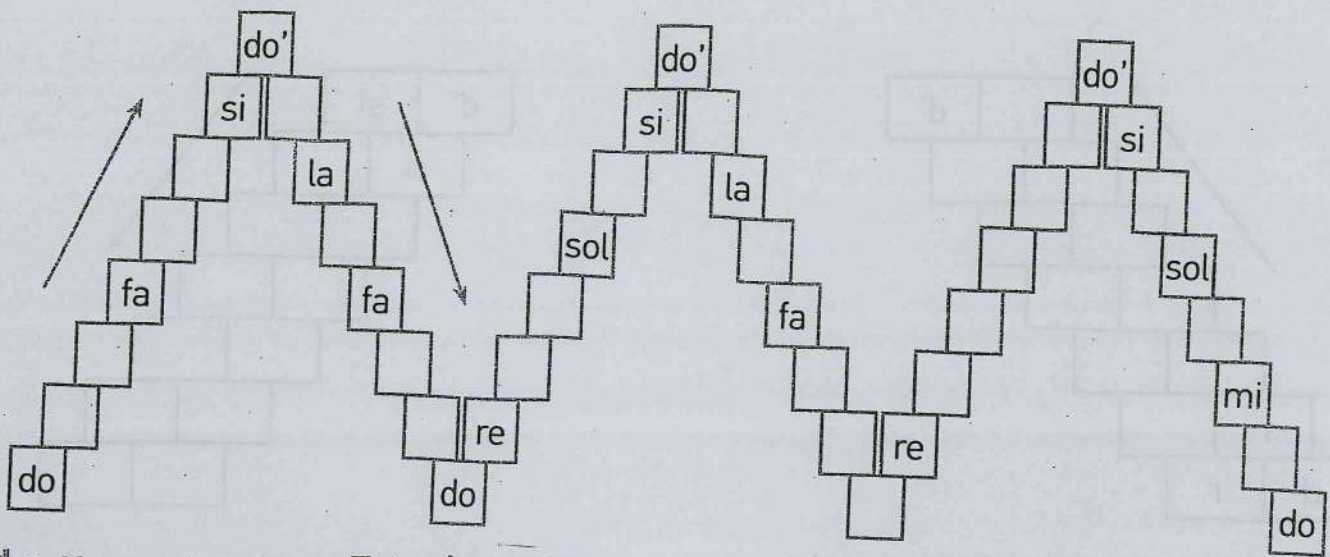

**Solfegem i cantem «Totes les notes».**

To - tes les no - tes de l'es - ca - la ei - xi-ren hui a pas - se - jar.

Jo les he vis - tes molt con - ten - tes i no pa - ra - ven de can - tar:

do re mi fa sol la si do' do si la sol fa mi re do'.

VEU

CARILLONS

XILÒFONS

METAL·IÒFONS

2  Completem la sèrie.

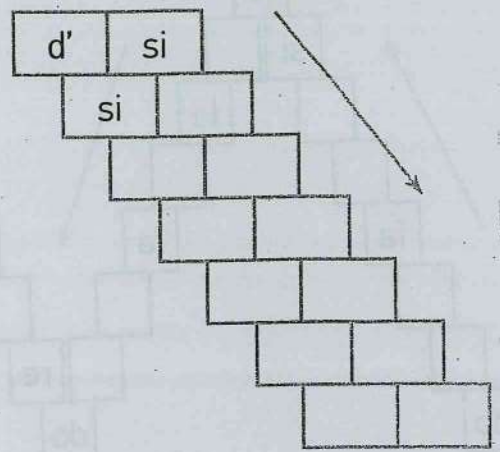
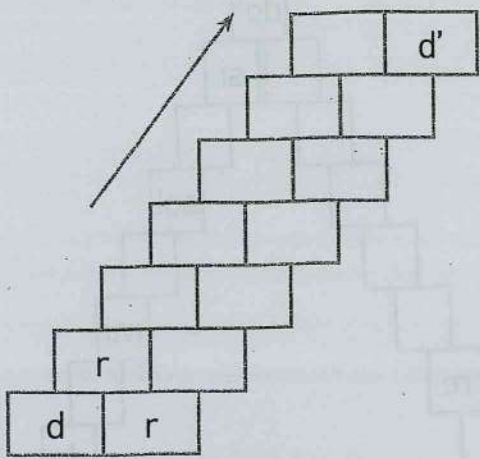

3  Repassem i dibuixem la clau de sol.

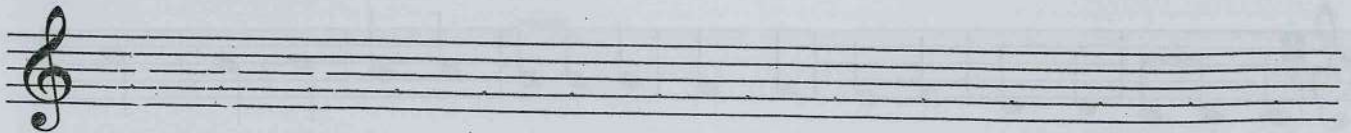

3  Escrivim el signe de compàs que pertoque.

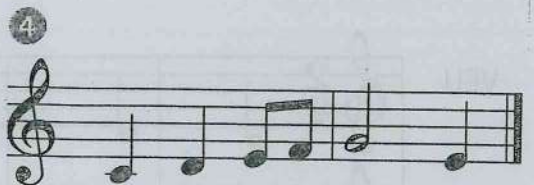
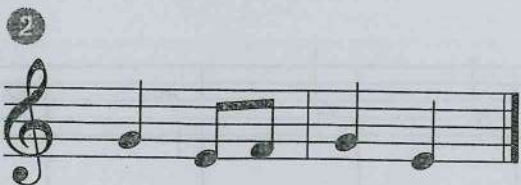
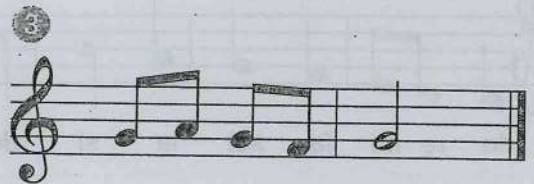
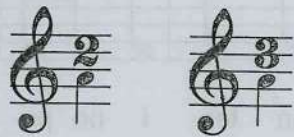

1 Compta les pulsacions que hi ha en cada pandereta i relaciona-les amb el compàs

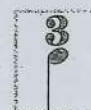

2. Dibuixa les pulsacions als ritmes següents. Pinta la que es toca i dibuixa les línies divisòries.

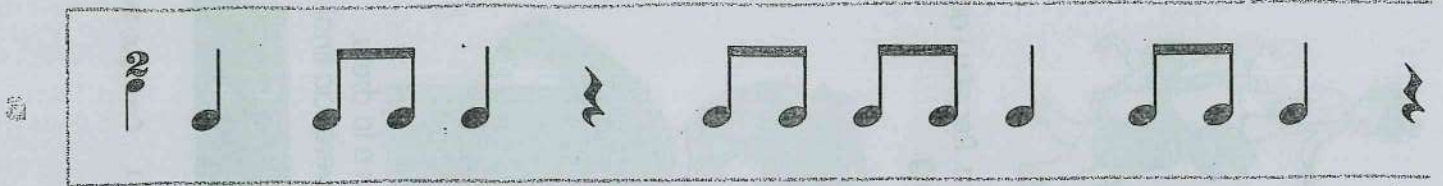

2. Fixa't en els cinc passos que seguim per dibuixar la clau de sol.

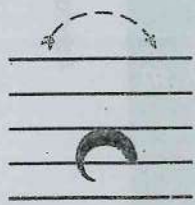

CAP



CARAGOL

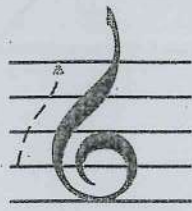

PUJA

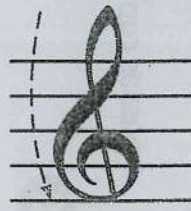

BAIXA

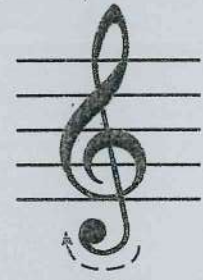

GIRA

3. Repassa cadascun dels passos.

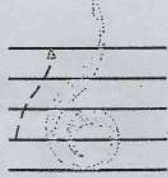
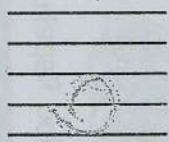
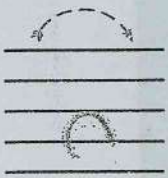

4. I, ara, a repassar.

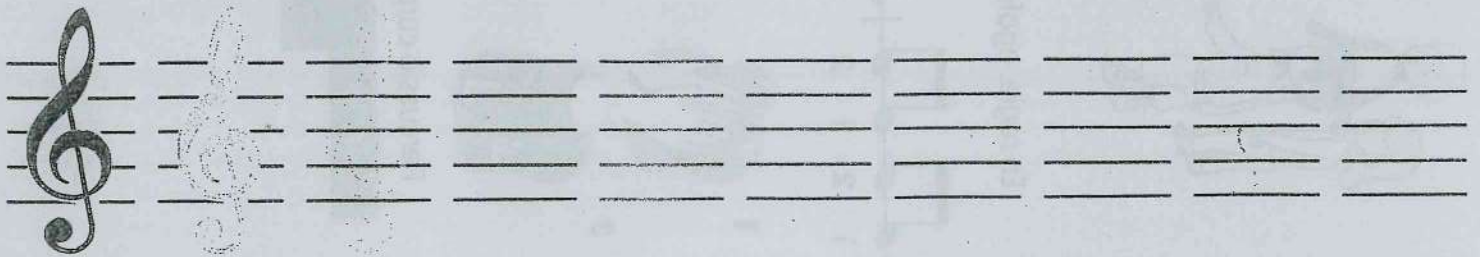

Jo sóc un ar - tis - ta que ha vin - gut de Pa - rís. Tu ets un ar - tis - ta que no has es - tat  
 lí. Sé to - car molt bé. Nos - al - tres tam - bé. Jo to - que la flau - ta xiu xiu xi  
 xiu

**3** Dibuixa la clau de sol.

**1** Passem al pentagrama i cantem «La pastora».

s s d' si l s m m f l s f s m s  
 Es - ta - ba\_u - na pas - to - ra, la - rán, la - rán la - ri - to, es -

s d' si l s m s s s s s d d  
 ta - ba\_u - na pas - to - ra cui - dan - do un re - ba - ñi - to.



Convierte las notas en o según convenga y canta la pieza:

**1** Escrivim el nom dels elements musicals i relacionem amb fletxes.

Indica quantes pulsacions hi ha en cada compàs.

Indica que s'ha de repetir la música.

Separa un compàs del següent.

Són cinc línies paral·leles on s'escriu la música.

Es col·loca al començament del pentagrama.

Es col·loca al final de la cançó.

**1** Passa al pentagrama la cançó «Aquestes muntanyes».

m f s l l s m f l s

A - ques - tes mun - ta - nyes que tan al - tes

m s s l si d' s s l s f m

són me'n pri - ven de veu - re mos a - mors on són.

Fixa't en els accents musicals i recita.

De cog - nom és da - ti - le - ra

i de nom es diu pal - me - ra.

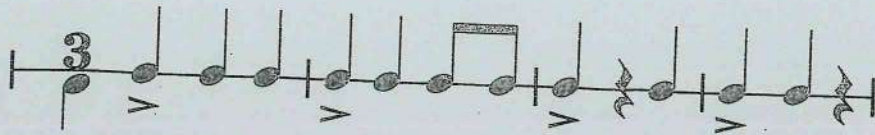

Tra-uen re - si-na del meu tronc al - tís-sim,

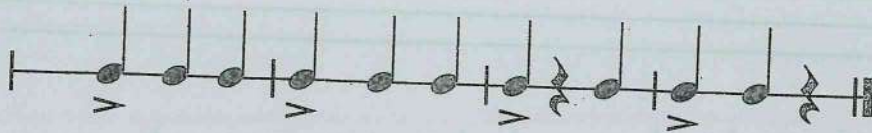

tra-uen re - si-na del meu tronc al - tís-sim,

## LÁGRIMA-F. TARREGA

A

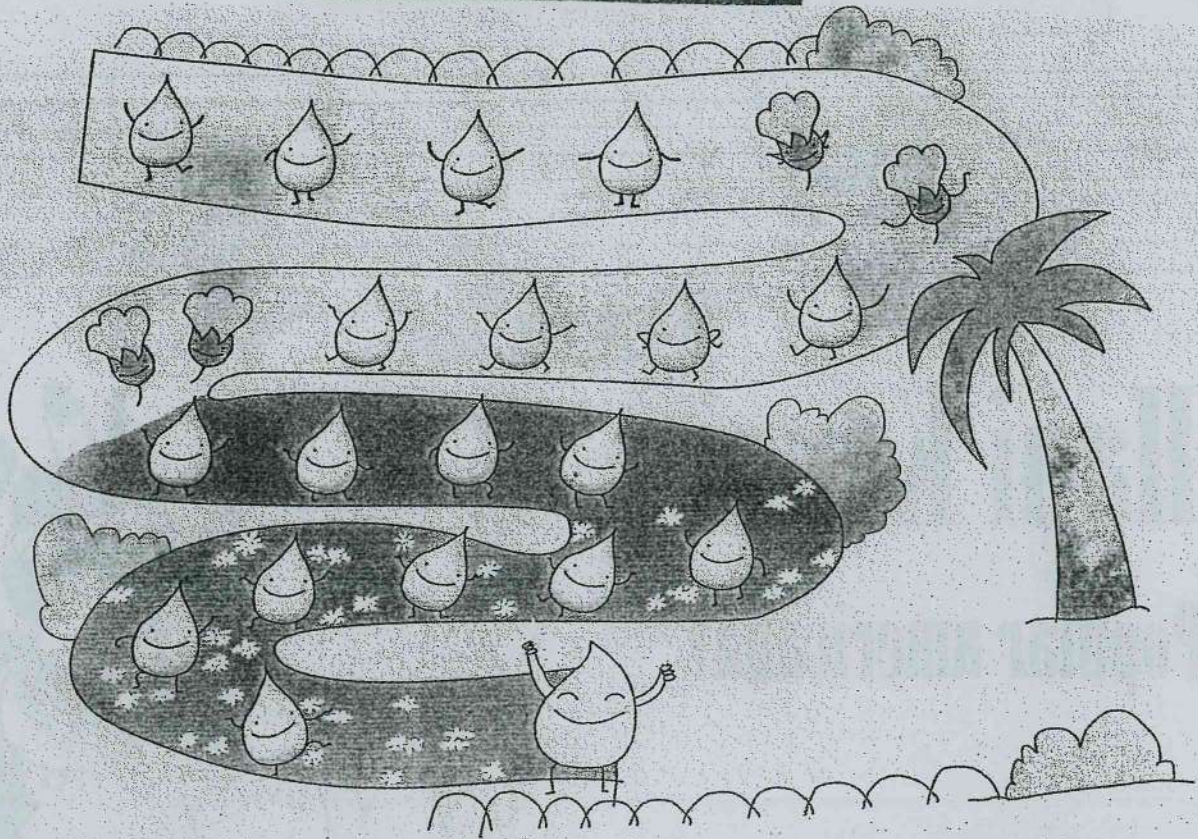

B

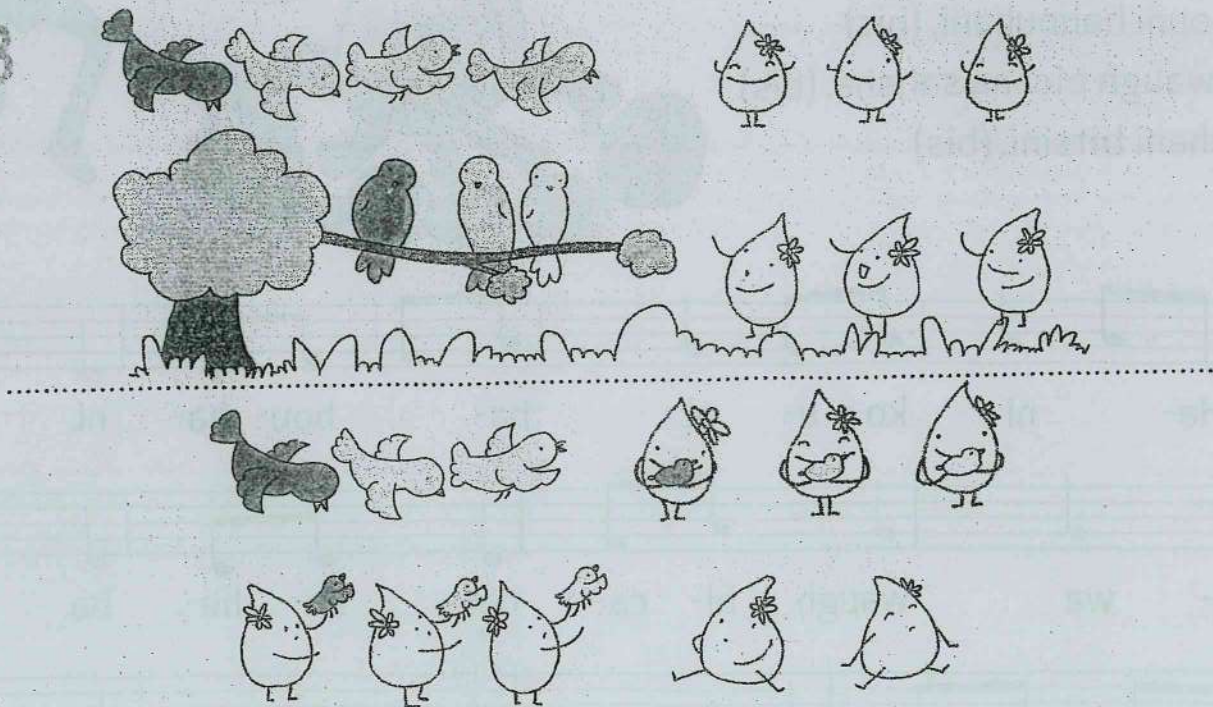

Forma: A-A-B-B-A

Practica la :



ol·loca les pliques i escriu el nom de les notes. Si vols escriure-les bé recorda açò:

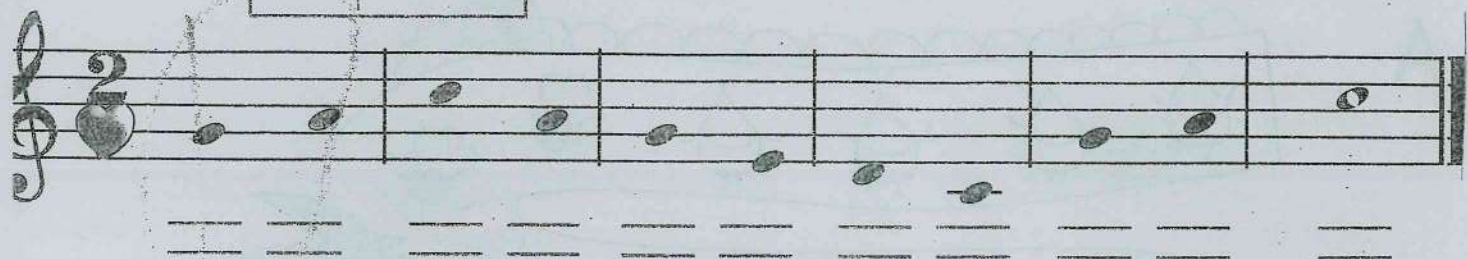
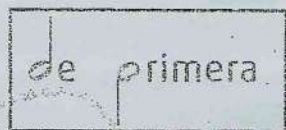

### UNITAT 3

# Hani Kouni

(Popular americana)

Hani kouni hahouhani. (bis)  
Hawa waugh bicana saheha. (bis)  
Hahouhani bitsini. (bis)

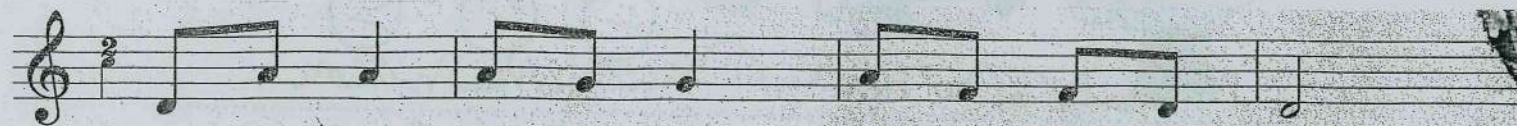

Ha- ni ko- u- ni ha- hou- ha- ni.



Ha- wa waugh bi- ca- na sa- he- ha.

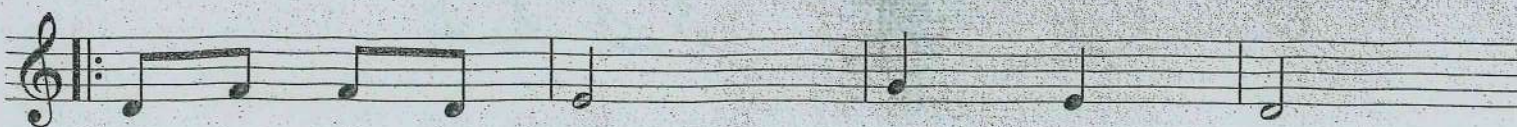

Ha- hou- ha- ni bit- si- ni.

# Les corxeres separades

Les **corxeres** es poden escriure separades.

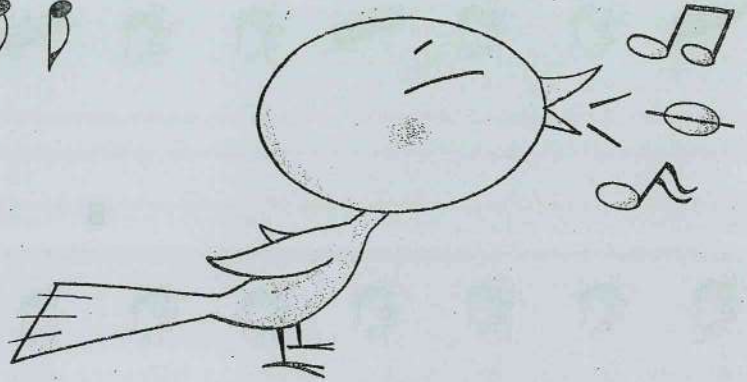

**1** Repassem i completem.

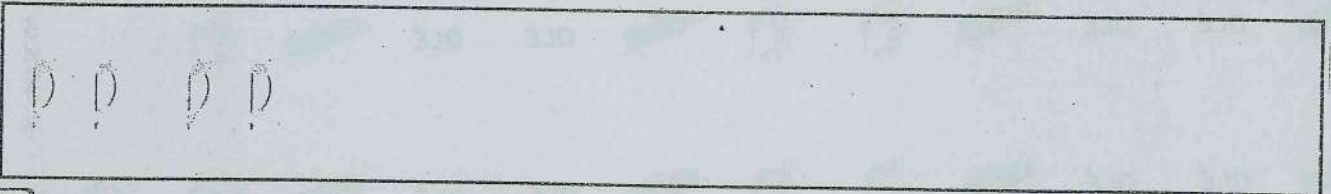
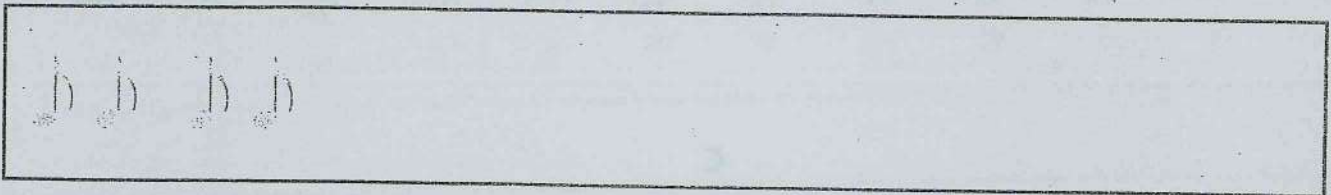

**2** Escrivim separant les corxeres.



Interpretació musical. *Olé, olé*

12. Interpreta aquesta peça musical amb els companys. Segueix les instruccions del professor.

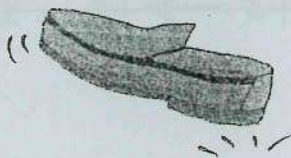

[ colp de taló ]



[ palmellada ]

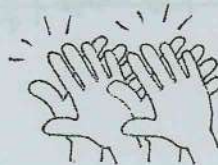

[ dues palmellades ]

[ pulsació ]

A

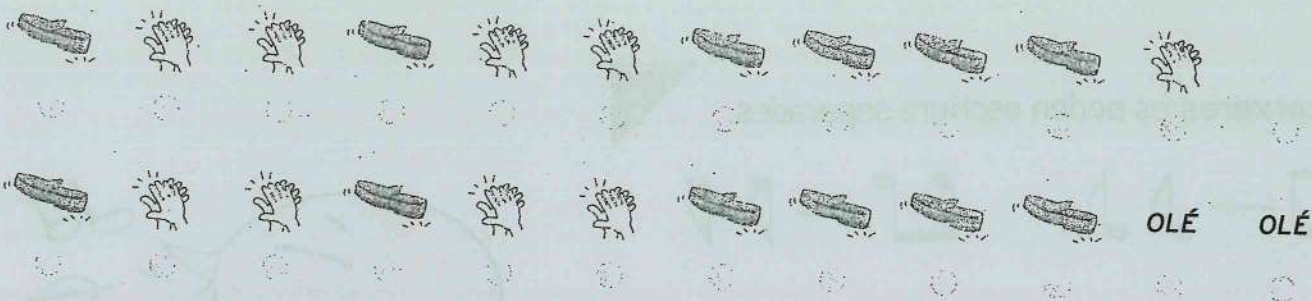

B

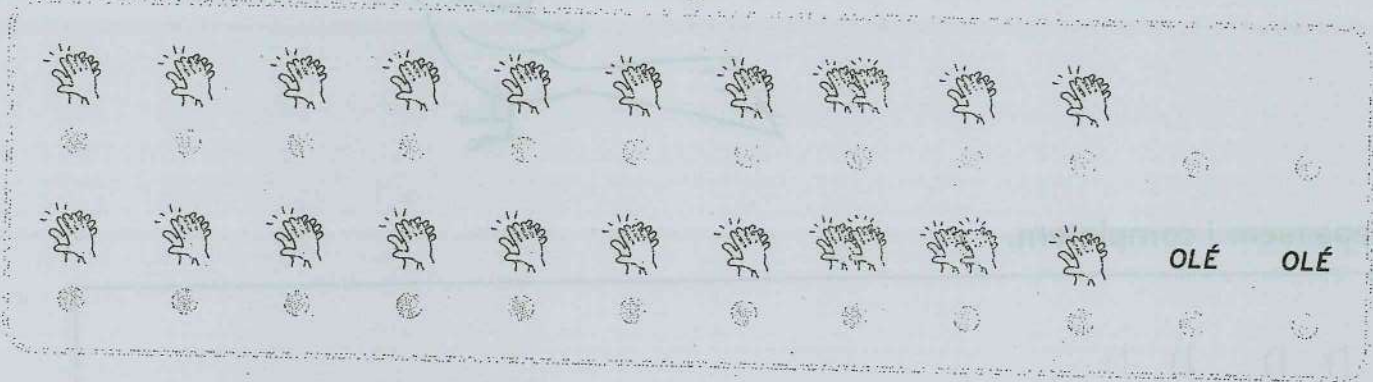

C

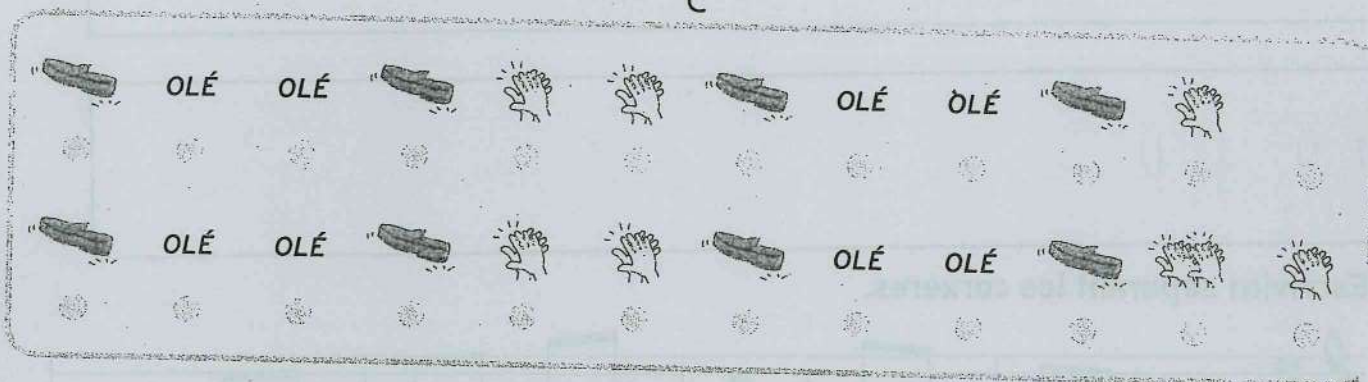

3. Forma quatre grups amb els companys. A cada grup li correspon un dels sons: colp d taló, palmellada, dues palmellades i olé. Interpreta de nou la cançó i participa nomé quan toque al teu grup.

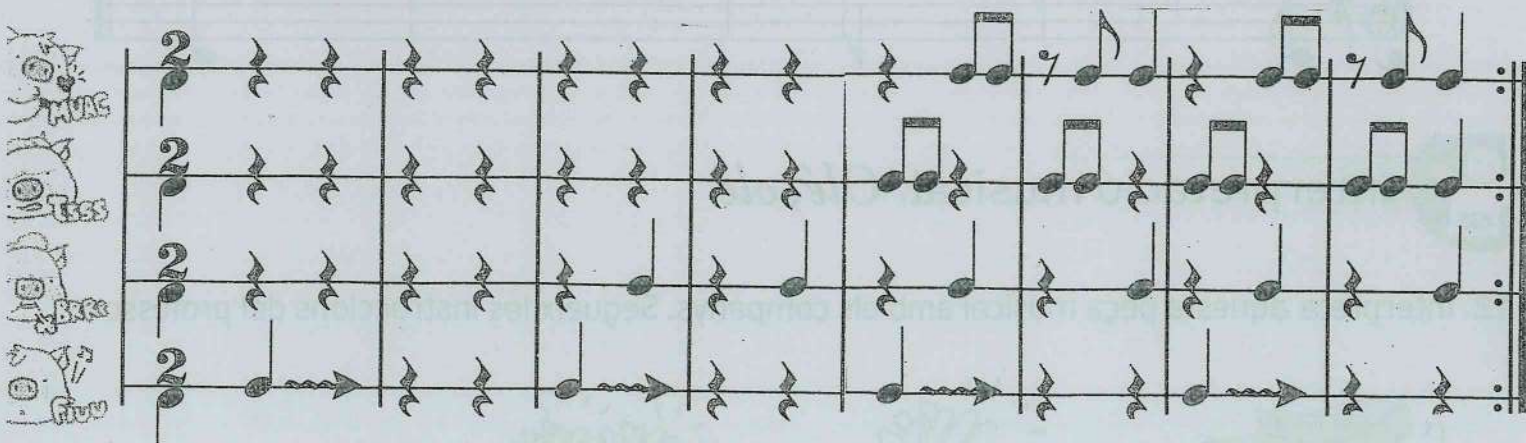

1 Acompanya la cançó «Hani Kouni» amb xilòfons.

VEU

Ha- ni ko- u- ni ha- hou-ha - ni.

ÒFON

ÒFON BAIK

VEU

Ha- wa waugh bi- ca- na sa- he- ha.

ÒFON

ÒFON BAIK

VEU

Ha- hou-ha- ni bit- si- ni.

ÒFON

ÒFON BAIK

2 Copia el fragment següent canviant les corxeres juntes per corxeres separades.



4. Escolta i escriu el número corresponent en cada maraca.

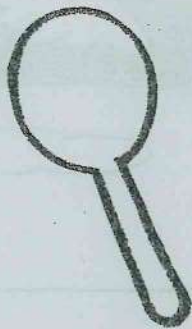
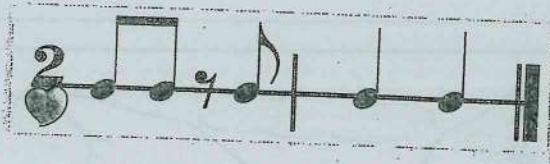
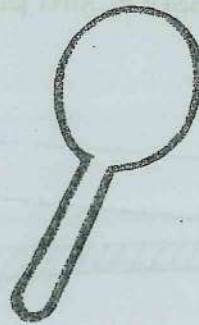
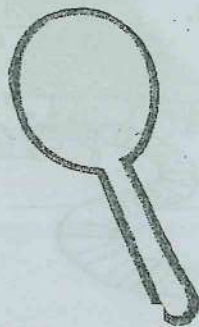
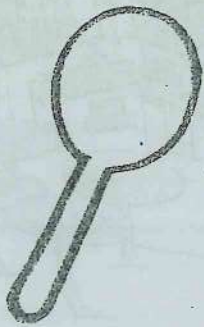

6. Repassa i escriu el nom de les notes.

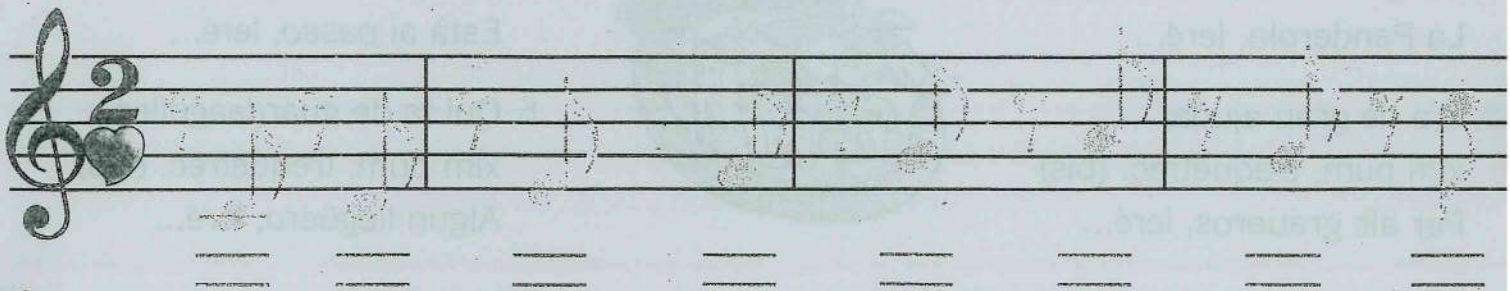

3. Escriu el nom de les notes.



4. Passa al pentagrama els sons següents.

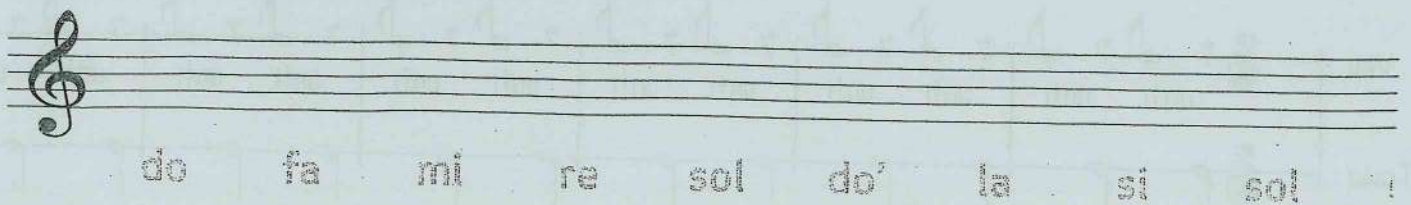

Aprende a dibujar el silencio de corchea siguiendo la línea punteada.



Segueix la pulsació de la música i escolta els canvis d'intensitat.

**A**

2 vegades

2 vegades

Fl

2 vegades

2 vegades

Repeteix tot fins a Fl.

			7	7	
6	la	6	6	6	
5	sol	5	5	5	
4	fa	4	4	4	
3	mi	3	3	3	mi
2	re	2	re		
1	do				

### Sweet as sugar, de Béla Bartók

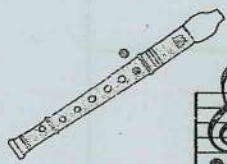

**Allegro**

*mf*

Organitzeu quatre grups per a interpretar els ritmes següents. Tres grups recitaran les frases dels pirates quan ho indique el professor, i un acompanyarà amb percussió corporal.

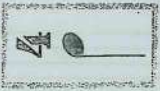

A

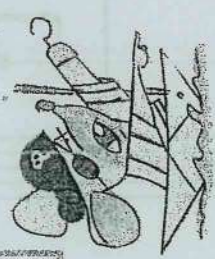

Pro - a, po - pa, ba - bord; es - tri - bord.

B

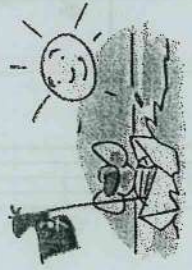

Vaig sol - cant les ai - gües bla - ves, na - ve - gant de ca - ra al sol.

C

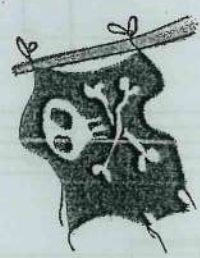

La ban - de - ra ne - gra amb la ca - la - ve - ra, dos tí - bies cre - ua - des te - la ma - ri - ne - ra!

D



Quatre **semicorxeres** tenen la mateixa durada que una negra.



**1** Soltegem i cantem «tin ton».

Tin ton ti - qui - ti - qui ton ti - qui - ti - qui ti - qui do mi sol  
tin ton ti - qui - ti - qui ton ti - qui - ti - qui ti - qui ton.

Acompanyem la cançó amb aquest *ostinato*:

palmes  
genolls (alternant)

**2** Encerclem la pulsació on sone

1 2 3 4

- Quin és el compàs de la cançó? .....
- Comença amb anacrusi? .....
- Quina és la nota més greu? .....
- I la més aguda? .....

E D E D E D E D E D E D E D E D  
E D E D E D E D E D E D E D E D etc.  
E D E D E D E D E D E D E D E D  
E D E D E D E D E D E D E D E D E D E D

**1** Escoltem i escrivim el ritme.



**2** Completem el quadre.

		blanca amb punt
	dues pulsacions	
		negra
Z		
	una pulsació	dues corxeres
		quatre semicorxeres
		silenci de blanca

**2** Escoltem i escrivim el ritme.



**1** Copiem la música.

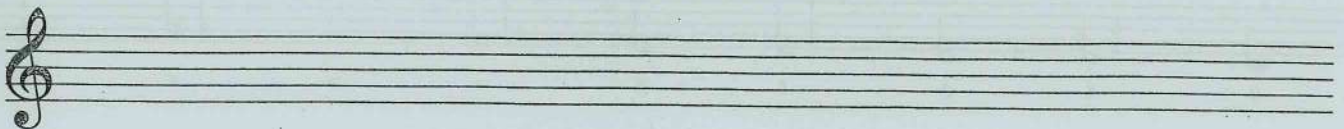
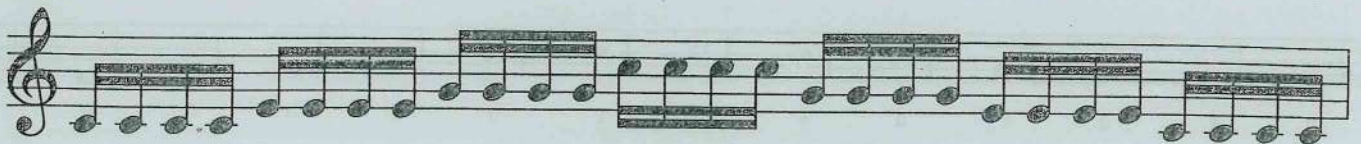

1

Cant

XII baix

Timbal

1a vegada

2a vegada

1a vegada

2a vegada

**2** Reconeixem.

1

2

3

4

a) 

			4
--	--	--	---

b) 

			4
--	--	--	---

c) 

			4
--	--	--	---

**1** Col·loquem línies divisòries i copiem la música.

**2** Dibuixa figures o silencis per a completar els compassos incomplets.

anta i posa les línies divisòries.

	dits	
	peus	
	palmes	
	cames	

**Dibuja la clave de Sol:**

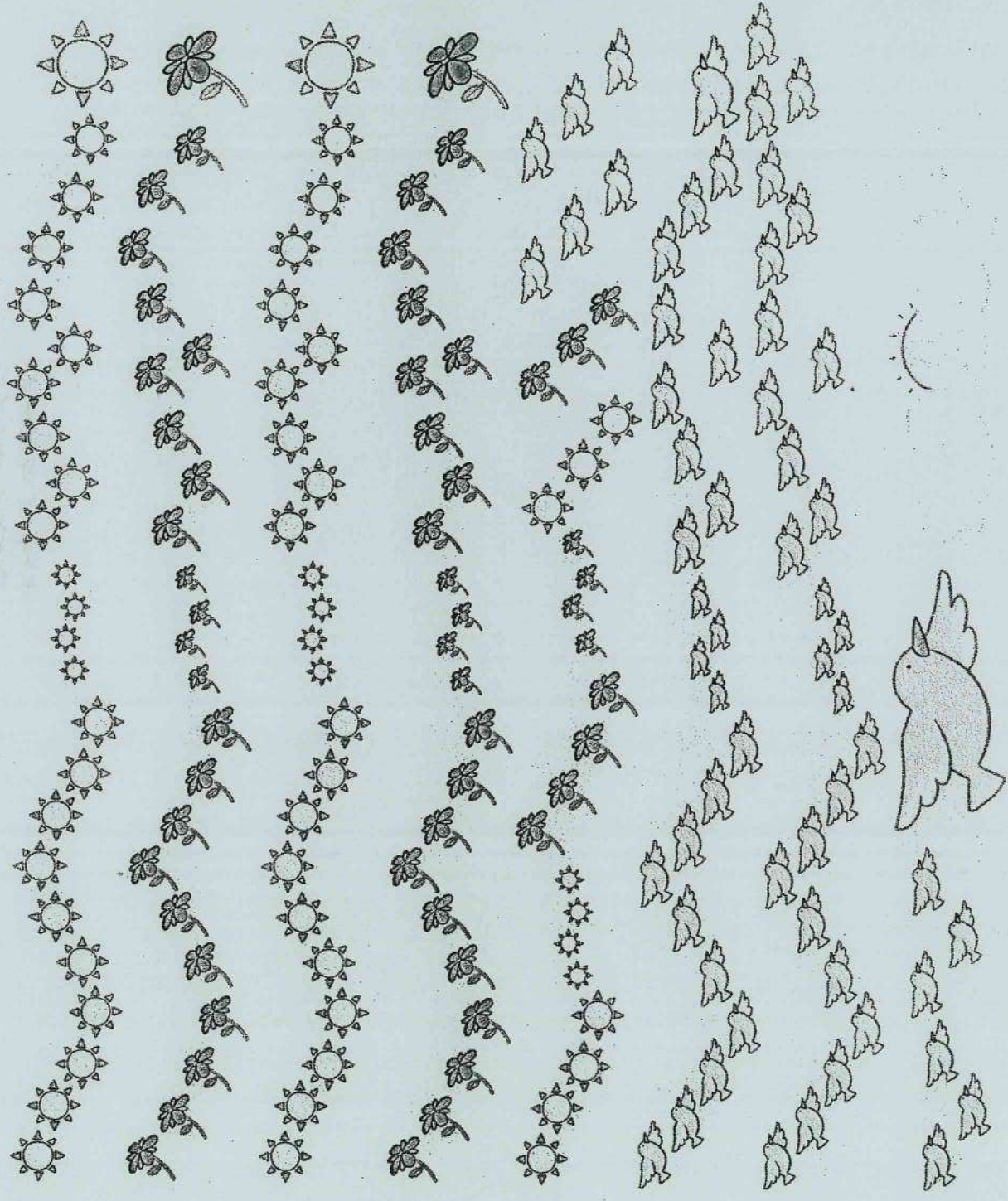
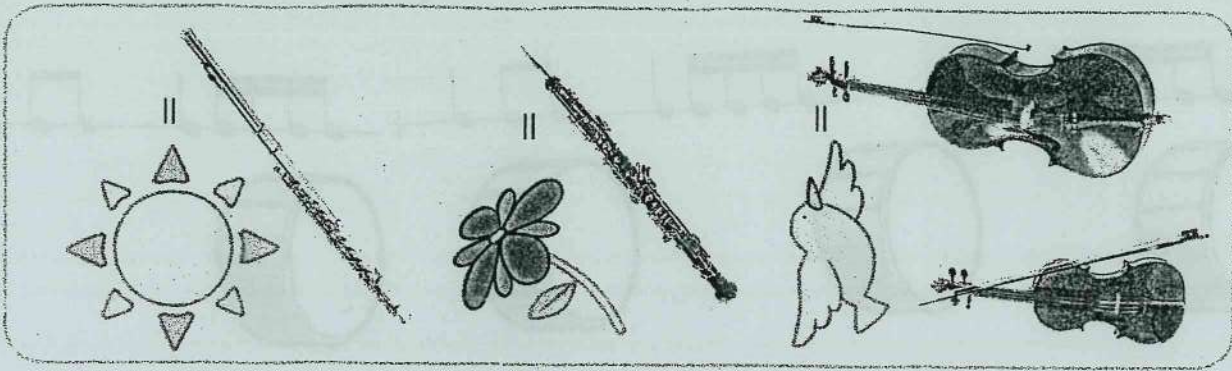

# UNITAT 5

1

## SÓC FELIÇ (J. Wuytack)

Sóc fe - liç amb el rit - me de la pau. Sóc fe - liç amb el rit - me de la pau. Sóc fe - liç - - Sóc fe - liç - - Sóc fe - liç amb el rit - me de la pau.

## 1 Solfegem i cantem «La flor de la cantuta» (Perú).

U - na flor de la can - tu - ta en el rí - o se ca - yó  
pú - so - se con - ten - to el rí - o su per - fu - me se lle - vó.

La flauta del pastor  
en el rí o se cayó,  
púsose contento el rí o  
y su música llevó.

El llanto de la niña  
en el rí o se cayó,  
púsose contento el rí o  
y sus lágrimas llevó.

El llanto y la cantuta  
y la flauta del pastor,  
pusieron contento al rí o  
que ya no los devolió.

## 2 Inventem i completem les relacions.

esquerra  
dreta



Salutació 1



Salutació 2

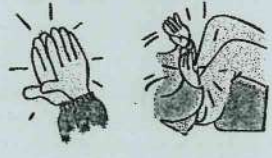

Volta

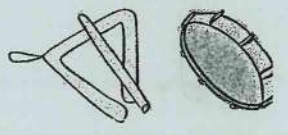

Passeig

2

2

1. Forma compassos de 2 temps:

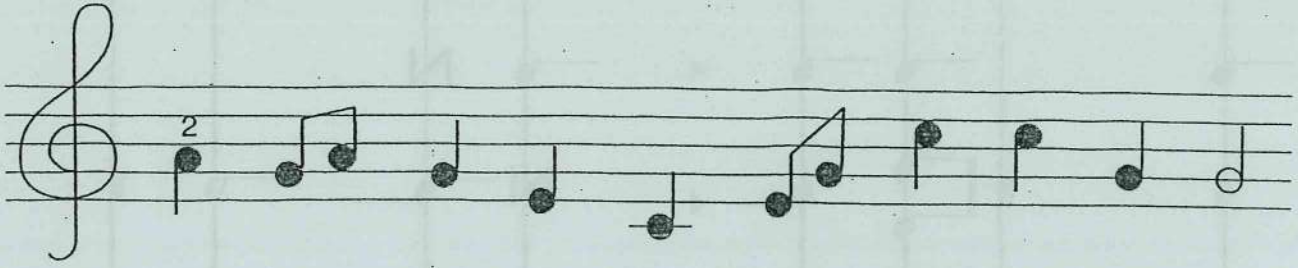

2. Forma compassos de 3 temps:

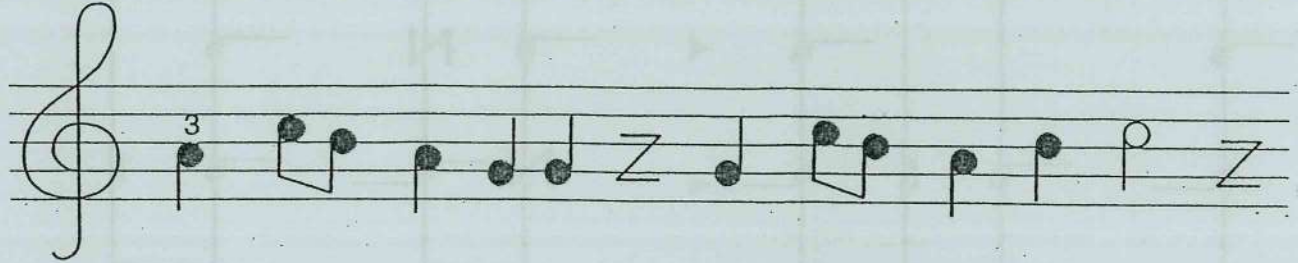

3. Forma compassos de 4 temps:

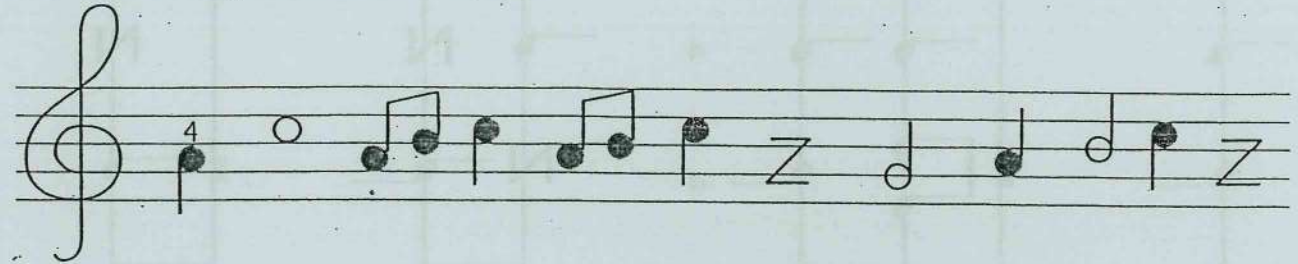

3

1

Relacionem els valors de les figures i dels silencis

○	♪ ♪ ♪ ♪	—	Z Z Z
♪.	♪ ♪	—	Z Z Z Z
♪	♪ ♪ ♪	—	Z Z
♪	♪ ♪		

Colorea de rojo los sonidos que encuentres que se llamen re y de verde las notas fa. Une los sonidos fa con una línea y saldrá una figura.

Six musical staves, each containing several notes. The notes are scattered across the staves, representing the letters 're' and 'fa' for a coloring activity. The notes are placed on various lines and spaces of the staves.

1. Ratlla el compàs que no sigui de 2 temps:

A musical staff in treble clef with a key signature of one flat. The staff contains a sequence of notes: a quarter note on G4, a quarter note on A4, a quarter note on B4, a quarter note on C5, a quarter note on B4, a quarter note on A4, a quarter note on G4, a quarter note on F4, a quarter note on E4, a quarter note on D4, a quarter note on C4, and a quarter note on B3. A double bar line is placed after the first two measures, with a '2' above the first measure and a 'Z' symbol in the second measure, indicating a 2-measure rest.

2. Ratlla el compàs que no sigui de 3 temps:

A musical staff in treble clef with a key signature of one flat. The staff contains a sequence of notes: a quarter note on G4, a quarter note on A4, a quarter note on B4, a quarter note on C5, a quarter note on B4, a quarter note on A4, a quarter note on G4, a quarter note on F4, a quarter note on E4, a quarter note on D4, a quarter note on C4, and a quarter note on B3. A double bar line is placed after the first three measures, with a '3' above the first measure and a 'Z' symbol in the fourth measure, indicating a 3-measure rest.

3. Ratlla el compàs que no sigui de 4 temps:

A musical staff in treble clef with a key signature of one flat. The staff contains a sequence of notes: a quarter note on G4, a quarter note on A4, a quarter note on B4, a quarter note on C5, a quarter note on B4, a quarter note on A4, a quarter note on G4, a quarter note on F4, a quarter note on E4, a quarter note on D4, a quarter note on C4, and a quarter note on B3. A double bar line is placed after the first four measures, with a '4' above the first measure and a 'Z' symbol in the fifth measure, indicating a 4-measure rest.

Acompanya la música amb els ritmes que s'indiquen.

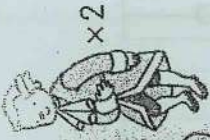

<b>A</b>	<i>f</i>	<i>p</i>	<i>f</i>	<i>mf</i>	<i>f</i>	<i>f</i>	<i>p</i>	<i>f</i>	<i>p</i>	<i>f</i>	<i>f</i>	<i>p</i>	<i>f</i>	<i>p</i>	<i>f</i>

x2      x2      x2      x2



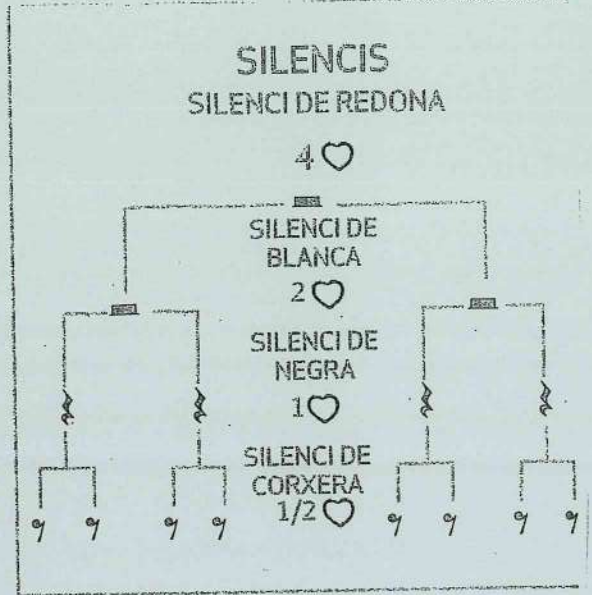
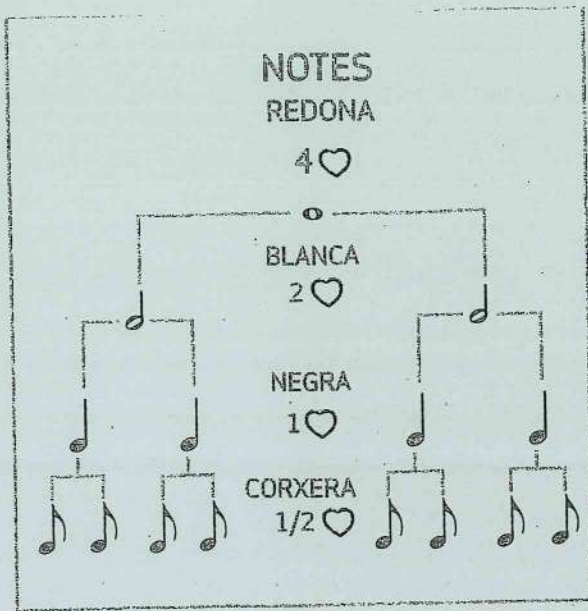

1 Fixa't en els quadres d'equivalències de les figures musicals i completa les igual següents.

a 1 ○ = 2 \_\_\_\_\_

c 1 ♪ = 2 \_\_\_\_\_

e 1 = 2 \_\_\_\_\_

b 1 ♪ = 2 \_\_\_\_\_

d 1 = 2 \_\_\_\_\_

f 1 } = 2 \_\_\_\_\_

2 Contesta.

a Quantes ♪ equivalen a una ○? \_\_\_\_\_

b Quantes ♪ equivalen a una ♪? \_\_\_\_\_

c Quantes ♪ equivalen a una ○? \_\_\_\_\_

d Quants silencis de = equivalen a un =? \_\_\_\_\_

e Quants silencis de ♪ equivalen a un =? \_\_\_\_\_



Convierte las notas en ♪ o ♪ según su altura.

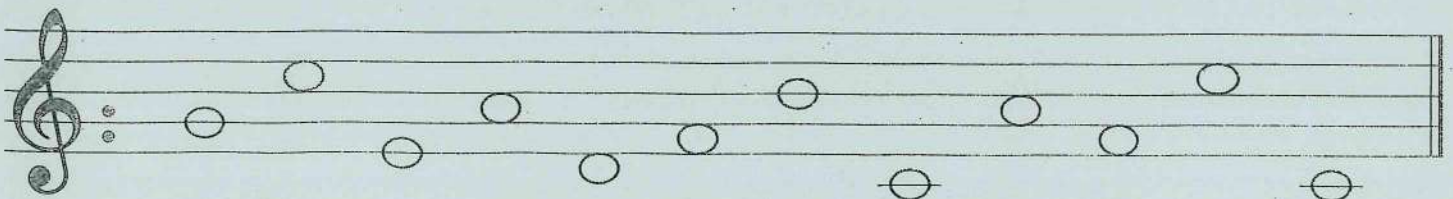



Canta las siguientes piezas marcando el compás:

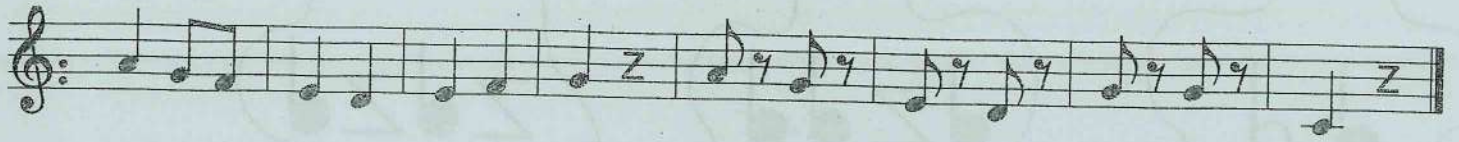

Dibuja el silencio de corchea 7 :

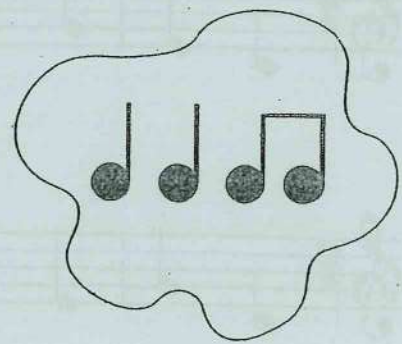
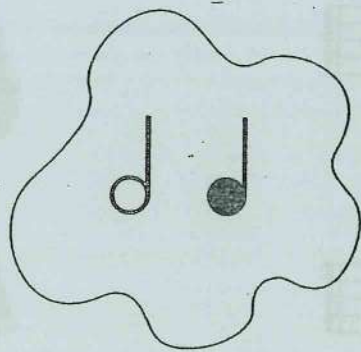
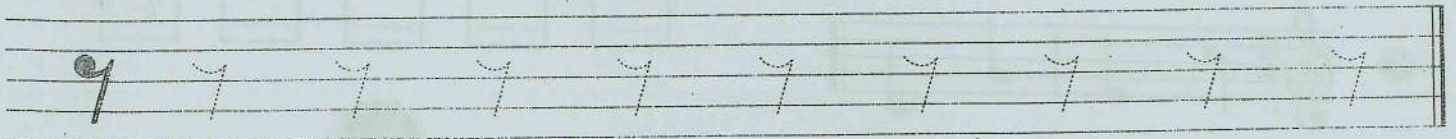

• Acoloreix: 3 temps → verd, 4 temps → groc.

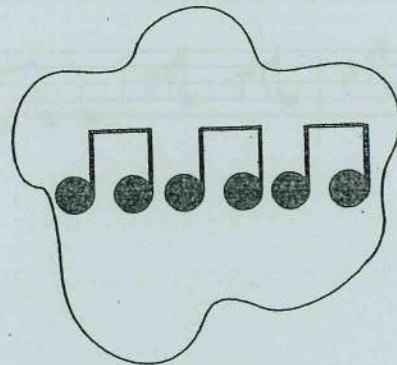
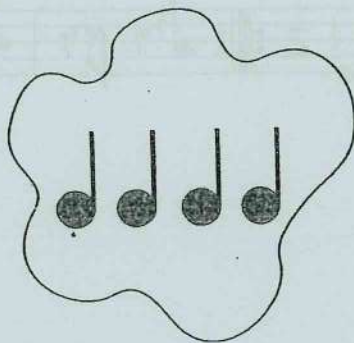
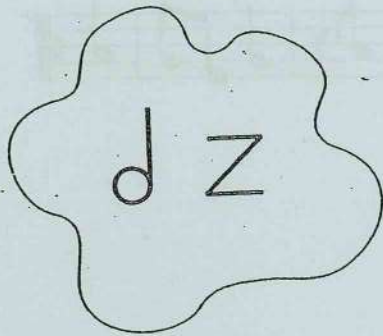
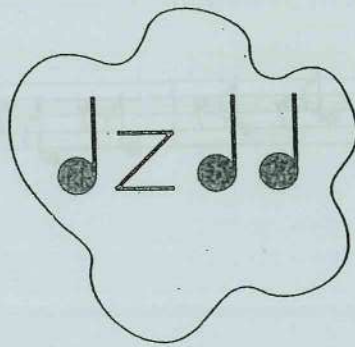
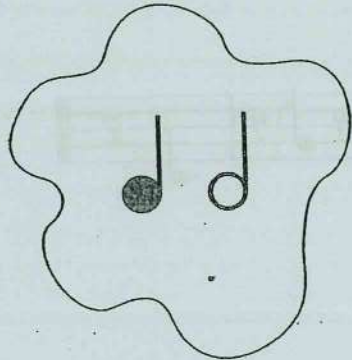
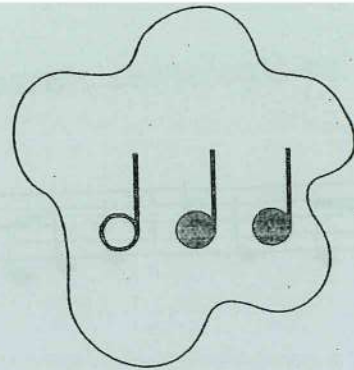
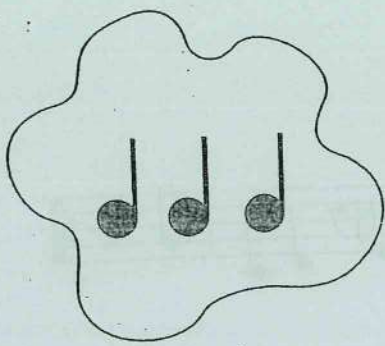

5.2 Reconeixem.

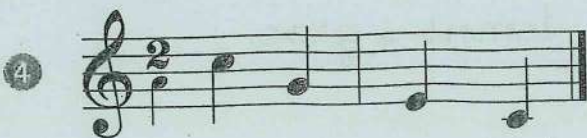
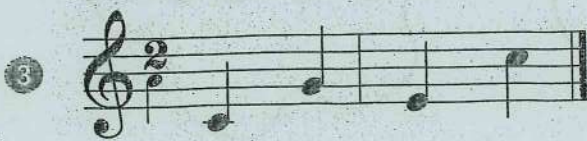
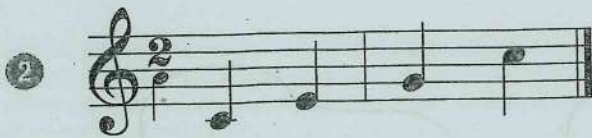
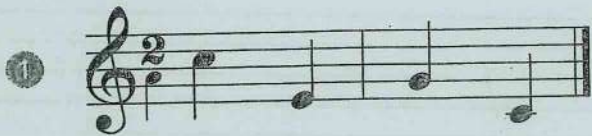

Completa y dibuja:

En la primera línea del



se coloca **Mi**

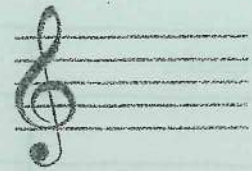

En la ..... línea del

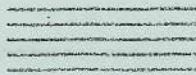

se coloca .....

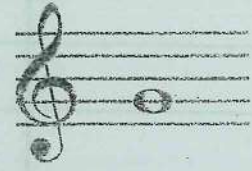

En el ..... espacio del



se coloca .....



En el ..... espacio del



se coloca **Do**

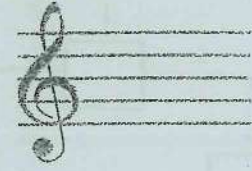

Debajo del

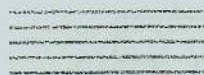

en una línea corta, se escribe .....

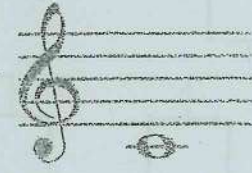

Escribe debajo de cada nota su nombre:

Líneas



Espacios



Debajo del pentagrama



Figura	Nom	Durada	Síl·laba rítmica

5 Completa el quadre d'equivalències des de la redona fins a la corxera.



Tu professor tocarà una serie de ocho notas entre las que pueden aparecer únicamente el Sol, el Do grave y el Do agudo. Escribe las en el pentagrama:

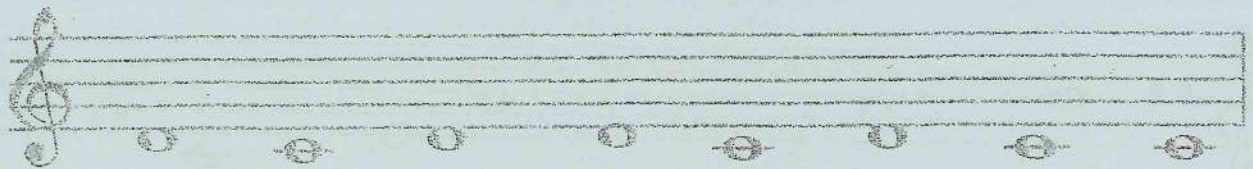
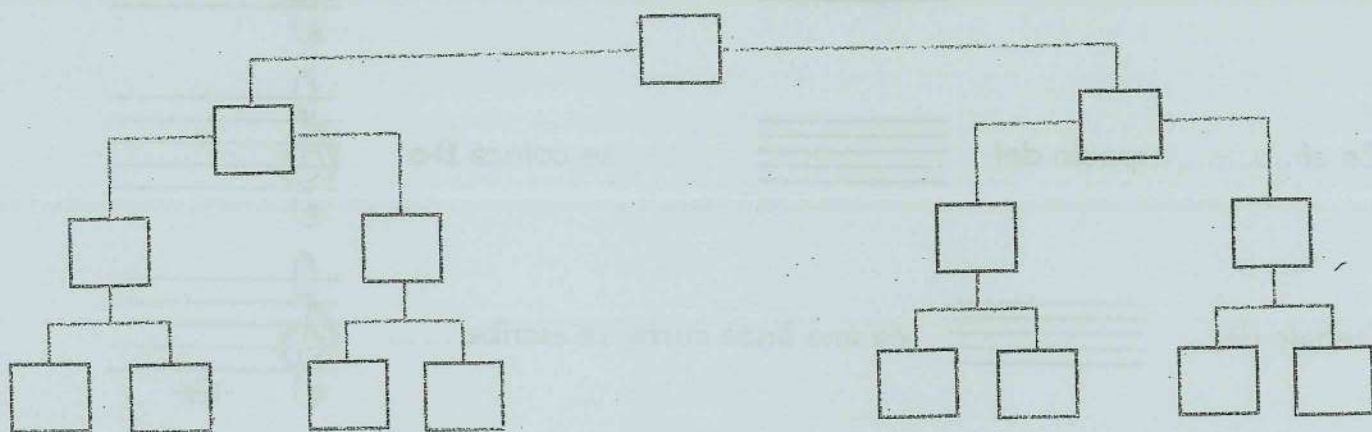
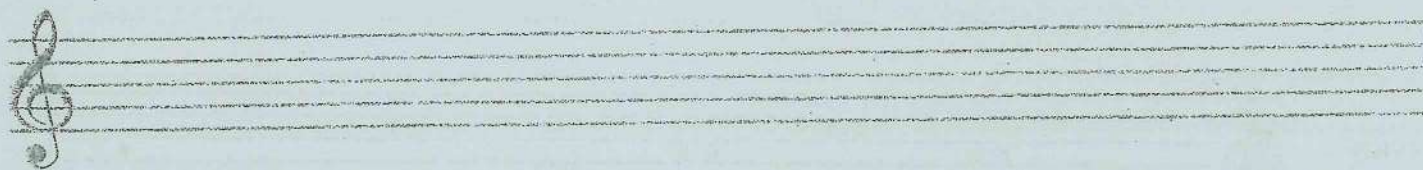

Completa poniendo el nombre debajo, o colocando la nota en su lugar.

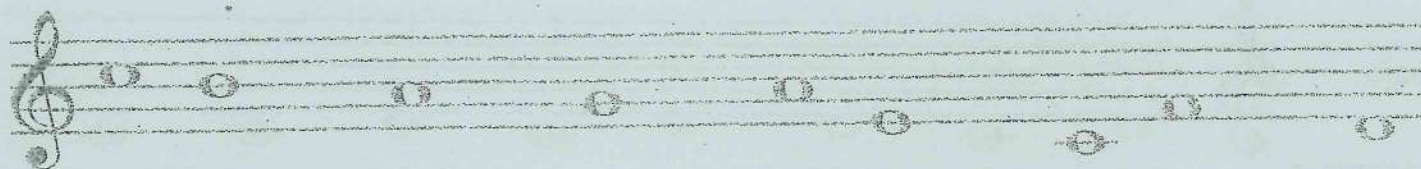

..... Fa ..... Do ..... Re ..... Mi ..... Si .....

11

1 Interpretar el ritme següent amb paraules i percussió corporal.

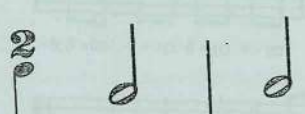
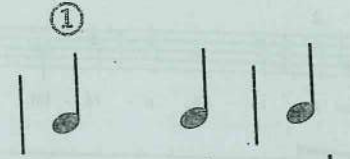
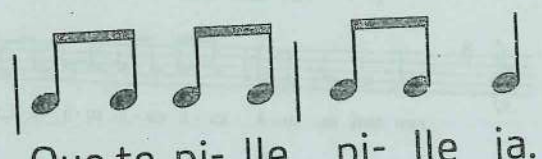
Cà - non                      mu - si - cal.                      Que te pi - lle, pi - lle ja.

XIULETS                      PALMES                      CAMES

Ara interpreta el ritme anterior en forma de cànon.

1

ram sam sam

Canta la cançó fent estos moviments:



Eram sam sam, eram sam sa,

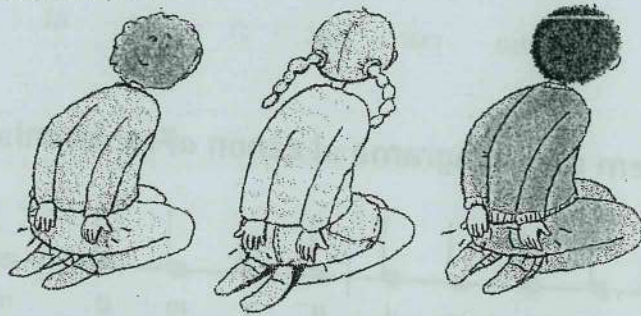

culi culi culi culi culi eram sam sa!



Aràbit, aràbit,

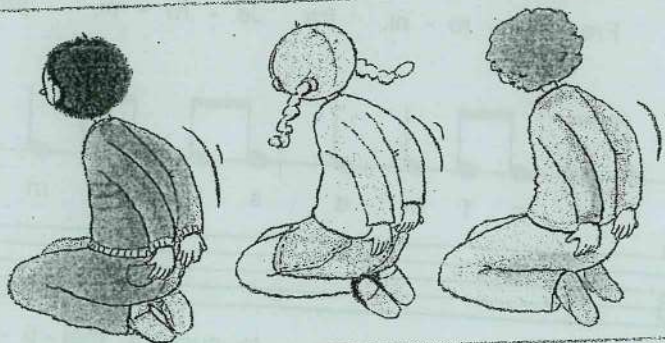

culi culi culi culi culi eram sam sa!

- Cantar una part de la cançó en veu alta i l'altra cantar-la per dins sense deixar de fer els moviments.
- Cantar la cançó a cànon. Després, alternar una part cantada amb un altra d'interioritzada.

Popular a Dakar

1  
E - ram sam sam, e - ram sam sa, cu - li cu - li cu - li cu - li cu - li\_e - ram sam sa! E - ram sam sam, e -

2  
ram sam sa, cu - li cu - li cu - li cu - li cu - li\_e - ram sam sa! A - rà - bit, a - rà - bit, cu - li cu - li cu - li cu - li\_e -

3  
ram sam sa! A - rà - bit, a - rà - bit, cu - li cu - li cu - li cu - li\_e - ram sam sa!

## Cansat estic

*Andante* DO SOL DO SOL7 DO SOL7

Do, re, mi, fa, sol, can - sat es - tic de sol - fe -

Do, re, mi, fa, sol,  
cansat estic  
de solfejar  
i no puc ja  
arribar al do...

DO SOL7 DO

rep. 3 vegades FI

jar i no puc jaar - ri - bar al do.

## 1 Passem al pentagrama el cànon «Fra Jeroni».

4

d r m d d r m d m f s m f s

Fra Je - ro - ni, fra Je - ro - ni, prou dor - mir, prou dor - mir

s l s f m d s l s f m d d s d. d s d

to - quen a mai - ti - nes to - quen a mai - ti - nes, din don dan din don dan.

1 Torna a escriure les sèries següents utilitzant la barra de repetició. Fixa't en el model.

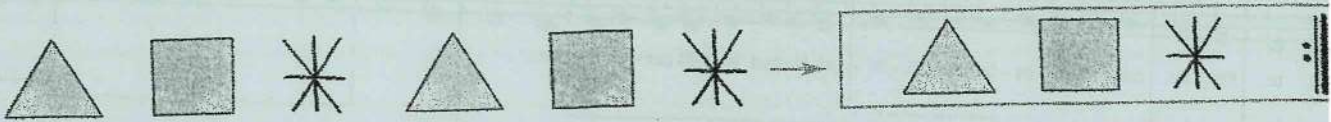
Ex 

a 

b A B C D A B C D 

c 

2 Fixa't en les frases musicals següents i escriu-les fent ús de la barra de repetició

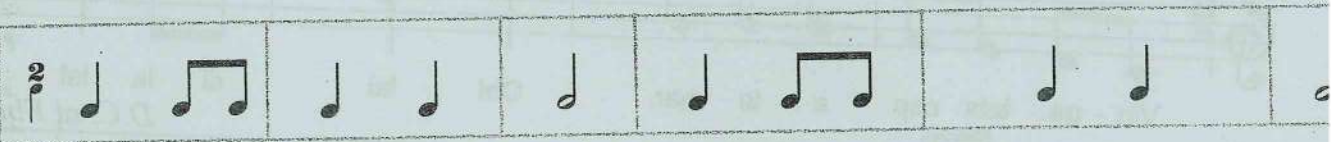
a 

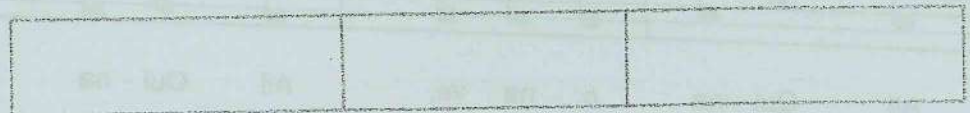

b 



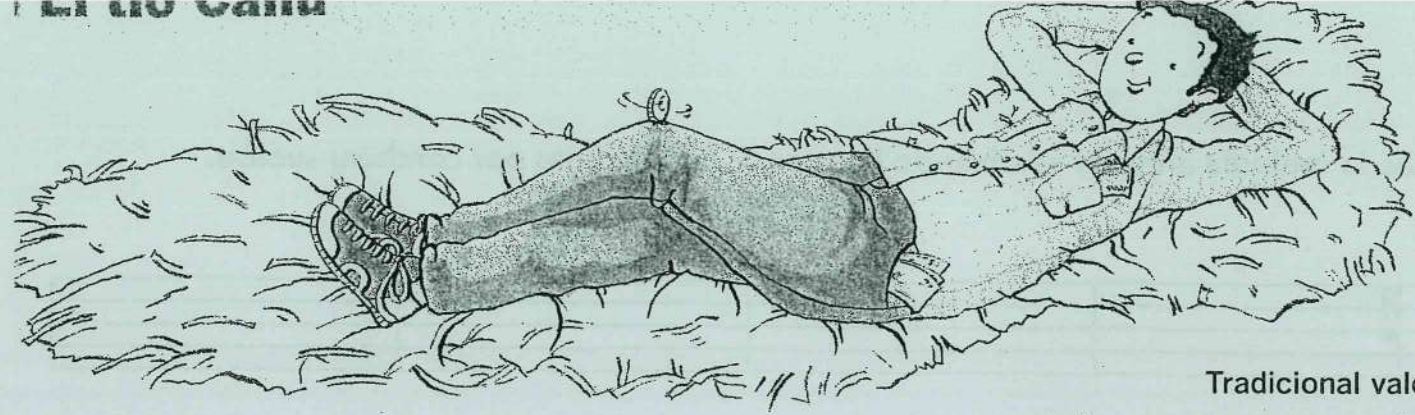

Tradicional valer

Hand-drawn musical notation with lyrics and triangle markers. Includes small hand-drawn sketches of hands above the notes.

l es diu que el tio Ca - liu és un gan - dul que no tre - ba -  
 que en - se - nya a les xi - que - tes a ba - llar en la ron - da  
 Di - ners, di - ners, i a a - pro - fi - tar - les to  
 di - ners, di - ners, com fan els bo - ti - guer

Assenyalem la resposta correcta.

Musical notation with lyrics: Pa oli sucre mel :| tomata sal

- Pa - oli - sucre - mel - tomata - sal.
- Pa - oli - sucre - mel - pa - oli - sucre - mel - tomata - sal.
- Pa - oli - sucre - mel - pa - oli - tomata - sal.

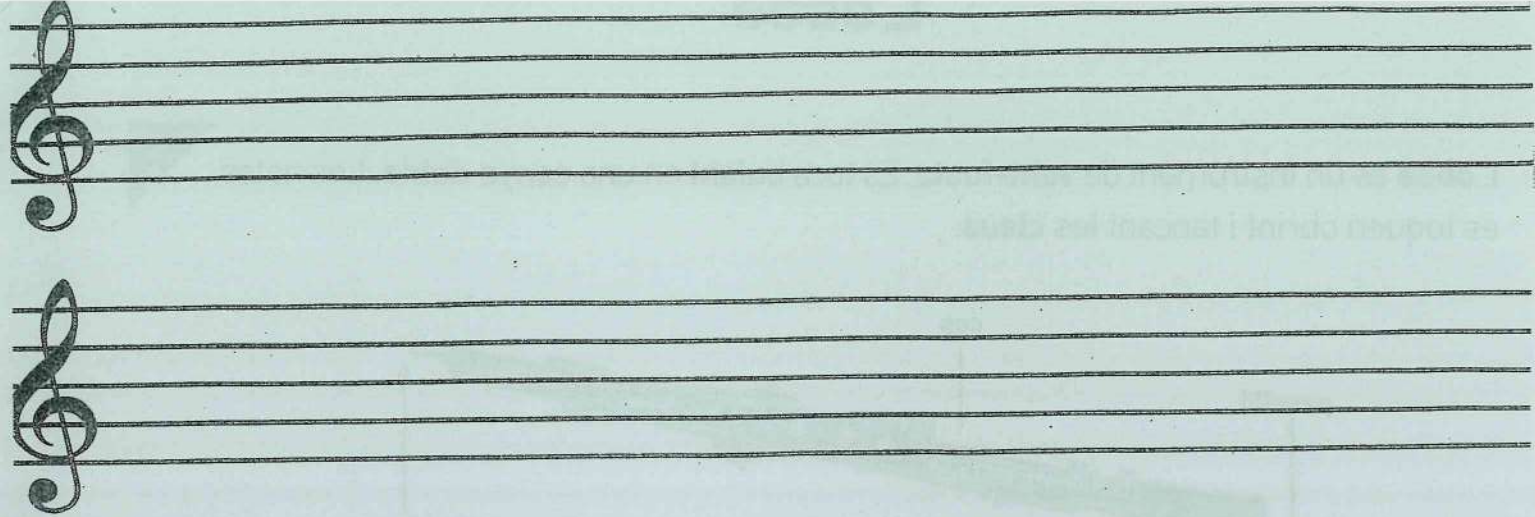

3 Escrivim la resposta correcta.

		1v.			2v.		
		Flauta	clarinet	guitarra	piano	trombó	trompa

flauta - clarinet - .....

4 Escoltem «El matí», d'Edvard Grieg.

A collection of musical instrument icons for a matching exercise. The icons include:

- 12 different types of flutes (piccolo, soprano, alto, tenor, bass).
- 1 violin.
- 8 sailboats on a sea.
- 8 empty square boxes with wavy lines representing water.
- 1 empty square box with a grassy field.
- 1 empty square box with a sun.
- 1 empty square box with a vertical line and three dots.

# L'OBOÉ

L'oboé és un instrument de **vent-fusta**. Es toca bufant en una **canya doble**. Les notes es toquen obrint i tancant les **claus**.

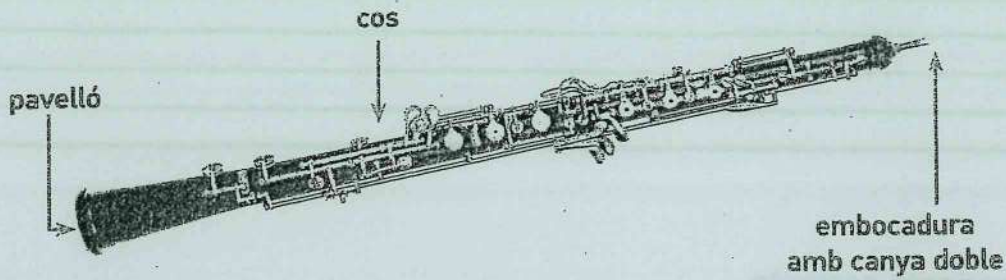

16

# El fagot

El **fagot** és el més gran dels instruments de **vent-fusta**. Es toca bufant. Té una embocadura amb canya doble com la de l'oboé. Les notes es toquen obrint i tancant les claus.

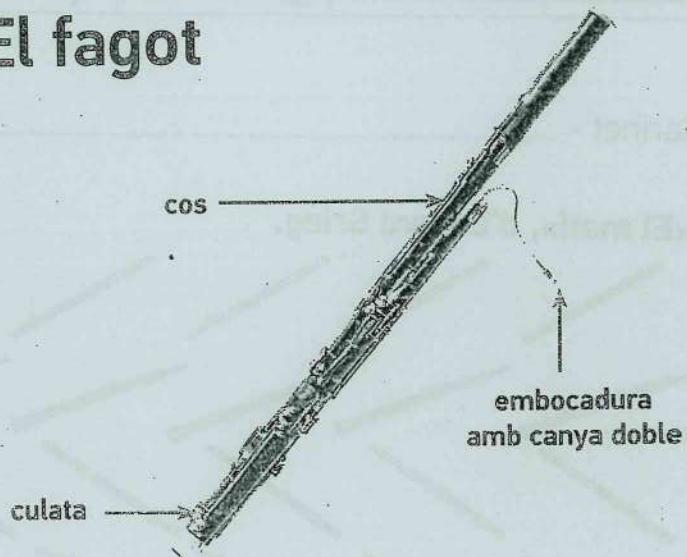

 Escoltem el «Concert per a fagot», d'Antonio Vivaldi.

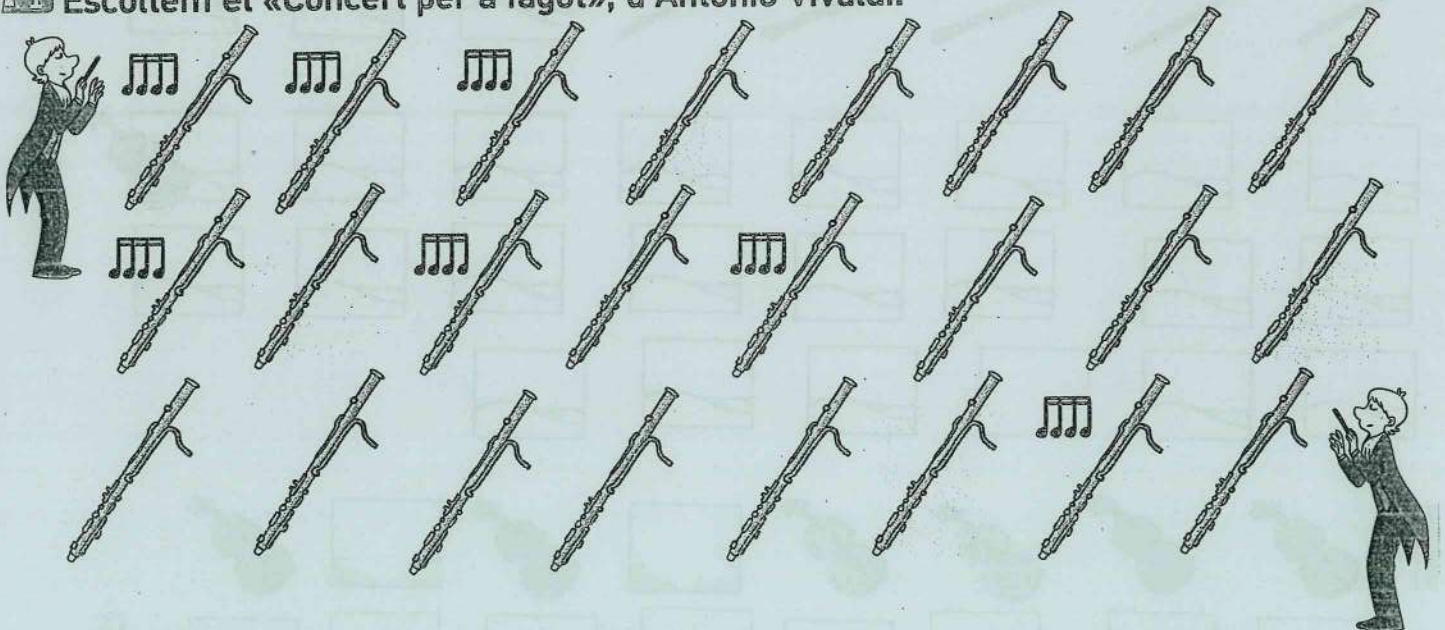

# Pepe Tono

1. -Pepe Tono, cull-me pomes.  
 -Concepció, que altes que estan. (bis)  
 Si les branques no s'acatxen,  
 pomes no se'n colliran. (bis)

2. Pepe Tono, Pepe Tono,  
 ha vingut ací al Verger (bis)  
 a demanar-li la xica  
 al tio Pepe el corretger. (bis)

3. El tio Pepe li contesta:  
 -Pepe Tono, no pot ser, (bis)  
 que la meua Francisqueta  
 és p'al Ganxo el sabater. (bis)

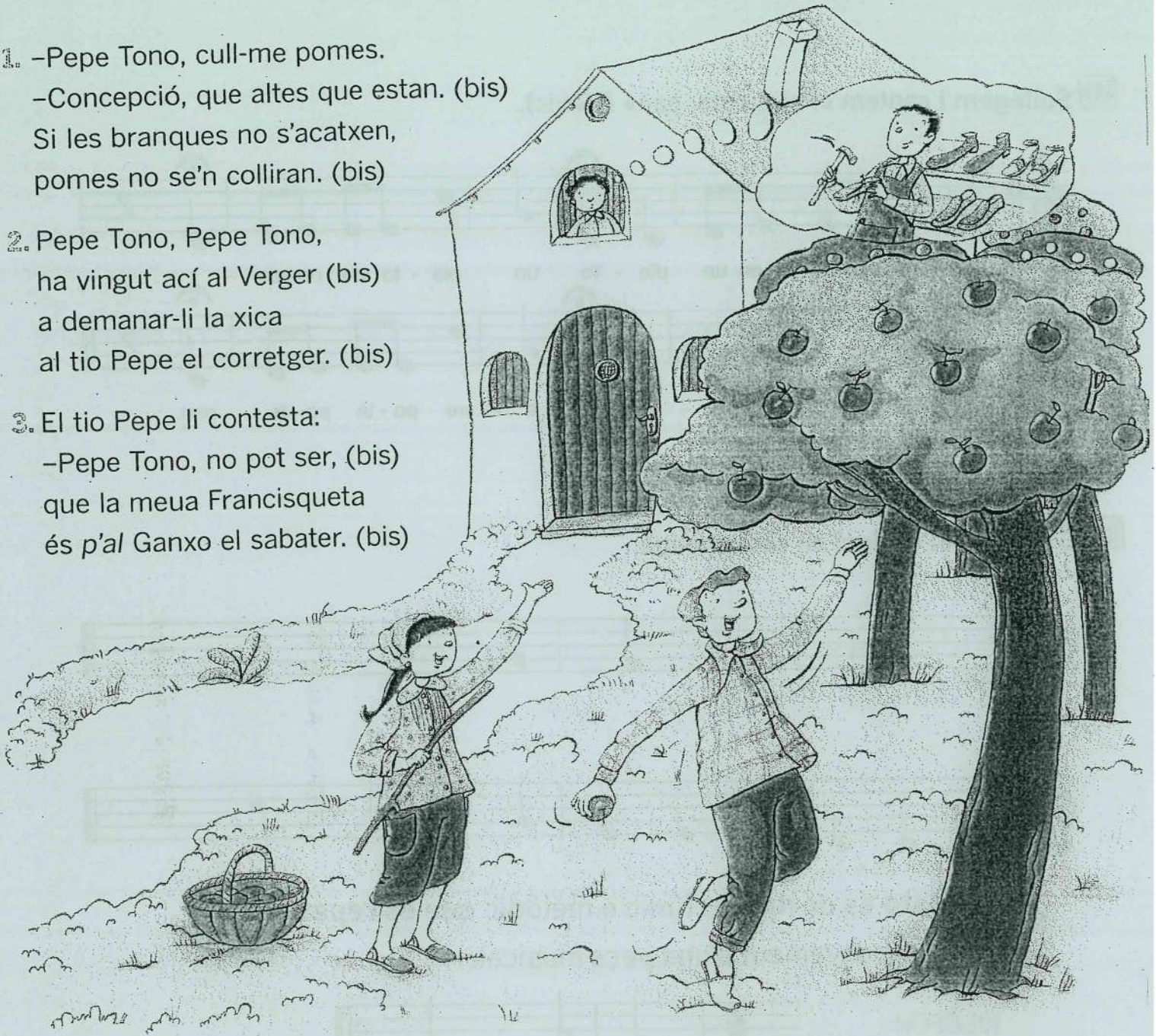

Musical notation for the song "Pepe Tono". The first line of music corresponds to the first verse of lyrics. The second line of music corresponds to the second verse of lyrics, with first and second endings marked with '1' and '2' respectively.

-Pe - pe To - no, cull - me po - mes. -Con - cep - ció, que al - tes que es - tan! Si les  
 bran - ques no s'a - cat - xen, po - mes no se'n co - lli - ran. no se'n co - lli - ran.

El **calderó** és un signe que es col·loca damunt d'una nota o silenci i n'allarga la durada.

 **Solfegem i cantem «Pote, pote, pan» (Mèxic).**



Un ga-to ca-yó\_en un pla-to un pla-to de un-za - -  
a - rre po - te po - te - po - te, a - rre po - te po - te pan. -

 **Dibuixem el calderó on corresponga.**

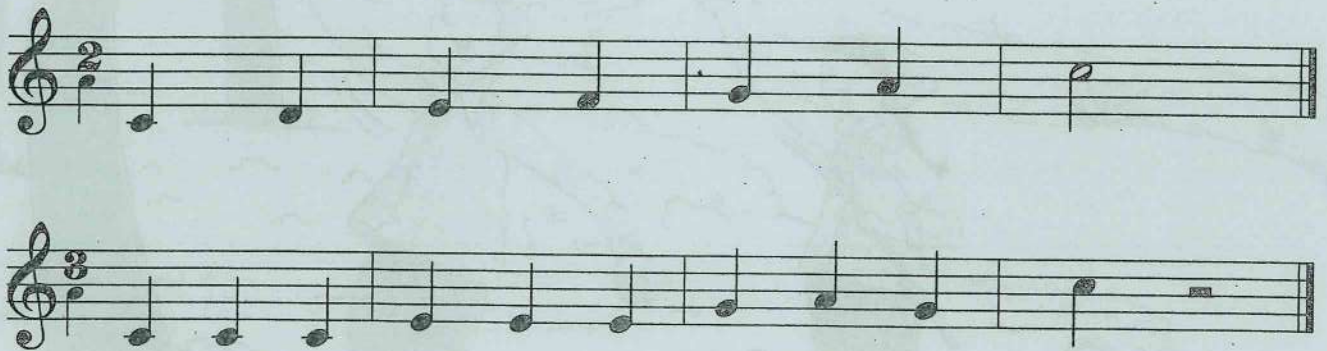

L'**ostinato** és un motiu rítmic o melòdic que es repeteix en l'acompanyament d'una peça musical.

XILÒFON

METAL·LÒFON

CAIXA XINESA

PANDERO

TRIANGLE

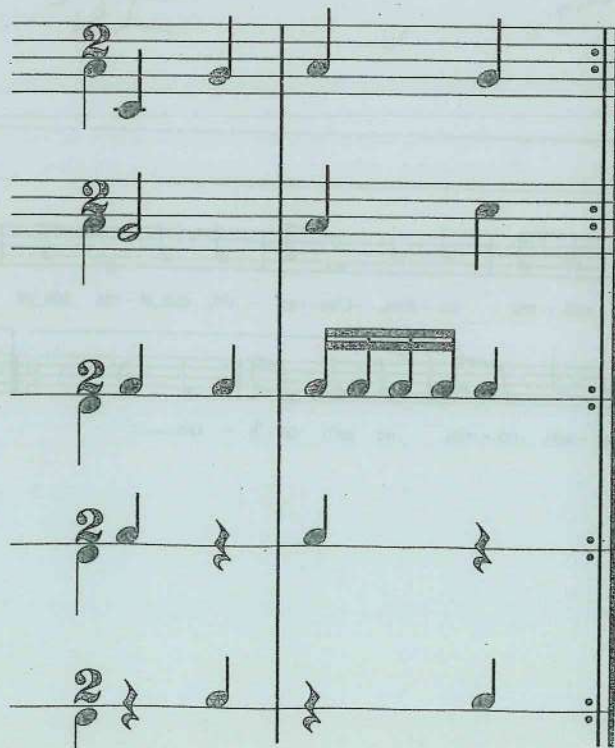

3 Completem la sèrie. Després, cantem-la tots junts.

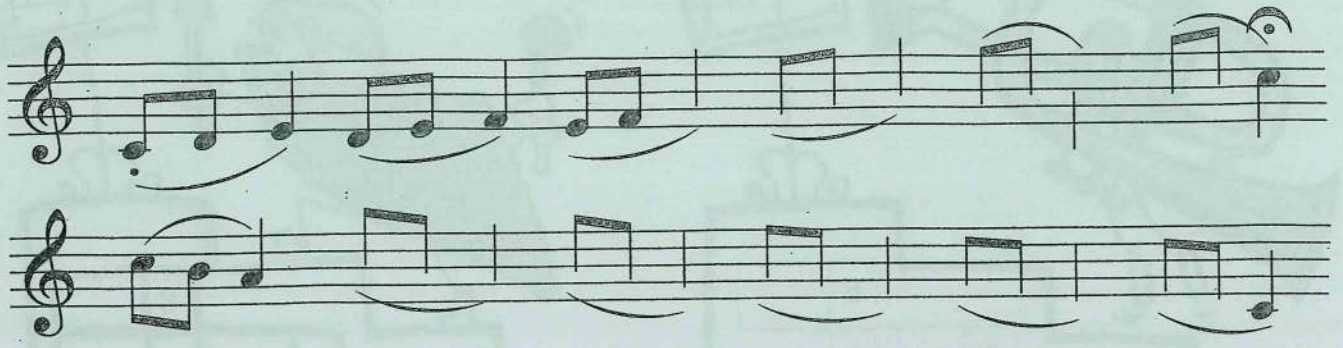

### L'INVERNO È PASSATO (Popular)



### Calderó

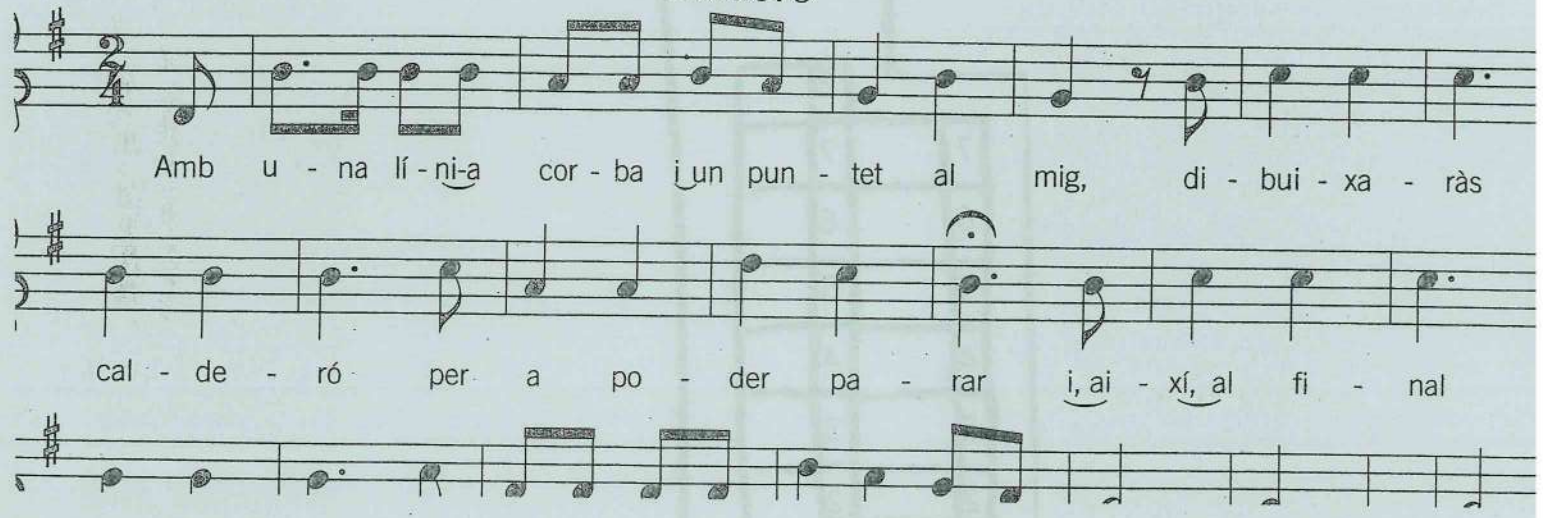

12 Escoltem i escrivim el ritme.

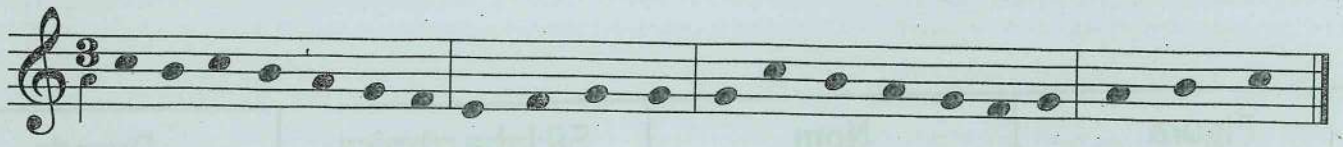

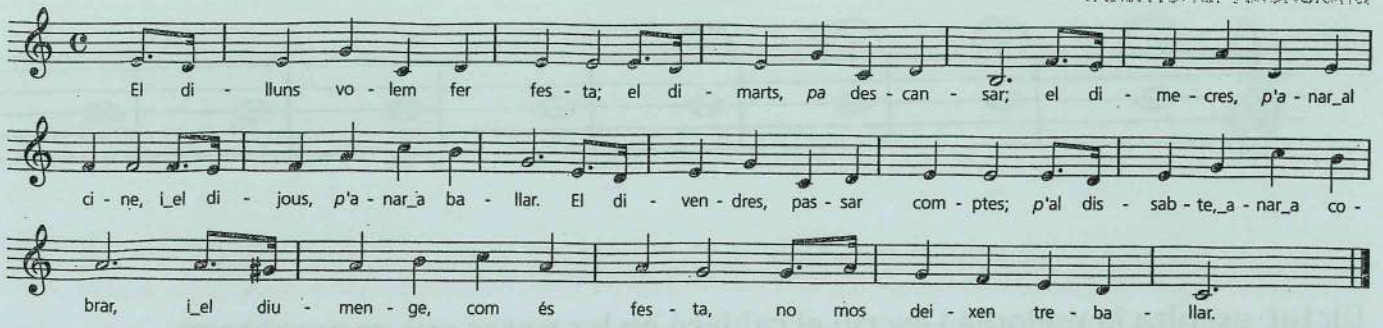

El di - lluns vo - lem fer fes - ta; el di - marts, pa des - can - sar; el di - me - cres, p'a - nar\_al  
 ci - ne, i\_el di - jous, p'a - nar\_a ba - llar. El di - ven - dres, pas - sar com - ptes; p'al dis - sab - te, a - nar\_a co -  
 brar, i\_el diu - men - ge, com és fes - ta, no mos dei - xen tre - ba - llar.



**Escrivim el nom dels elements musicals definits.**

El ..... és un conjunt de cinc línies on es col·loquen les notes musicals.

El signe que es col·loca damunt d'una nota i n'allarga la durada es diu .....

La ..... és un signe que es col·loca al principi del pentagrama.

Les cançons que comencen amb pulsació dèbil s'inicien amb .....

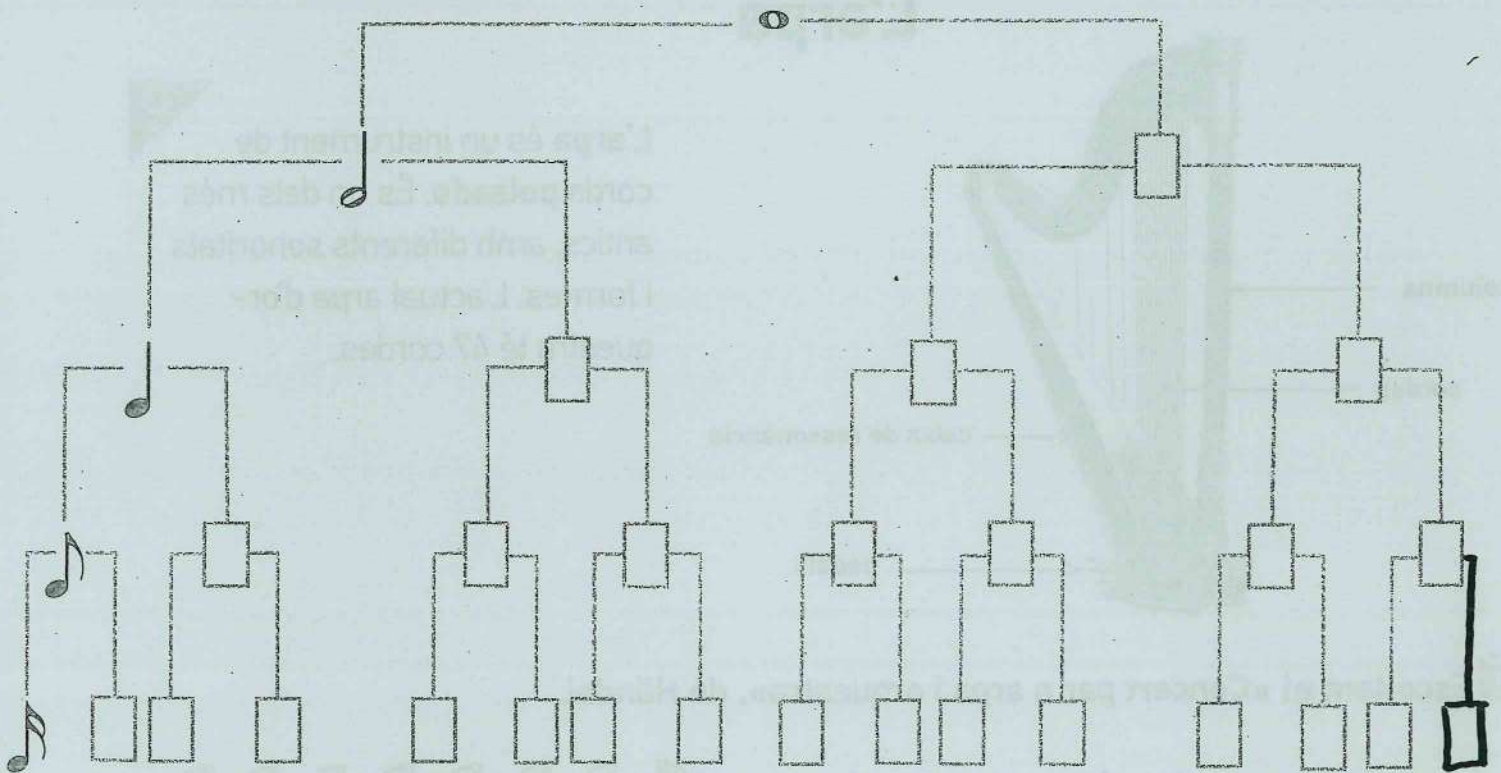

**b Completa.**

1 redona equival a \_\_\_ blanques, \_\_\_ negres, \_\_\_ corxeres i \_\_\_ semicorxer









**c Completa les igualtats següents.**

1  = \_\_\_       1  = \_\_\_       1  = \_\_\_       1  = \_\_\_

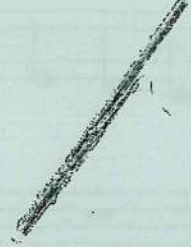
1  = 4 \_\_\_      1  = 2 \_\_\_      1  = 8 \_\_\_      1  = 16 \_\_\_

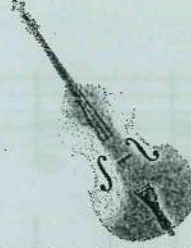
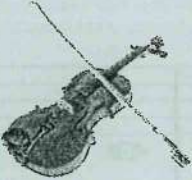

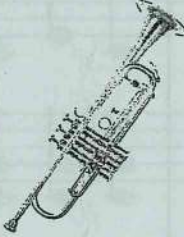
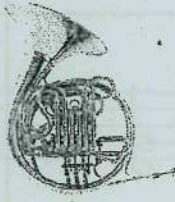
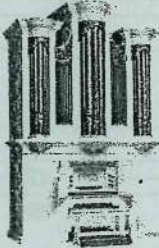
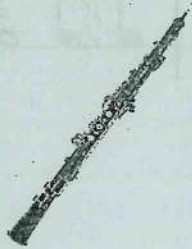
Escrivim el nom de l'instrument i la família a què pertany.

	flauta				
	vent-fusta				
					
					
					
					

Organitzo els sons següents perquè sons l'escala de do en sentit ascendent.

Musical notation on a staff showing a sequence of notes: a treble clef, a whole note on G4, a half note on A4, a quarter note on B4, a quarter note on C5, a quarter note on D5, a quarter note on E5, a quarter note on F5, and a quarter note on G5.

The musical score is divided into two systems. Each system has four staves: VEU (Voice), CARILLÓ (Chime), XILÒFONS (Xylophone), and PALETS (Clappers). The music is in 4/4 time and G major. The first system shows the vocal melody and accompaniment. The second system continues the piece, ending with a final vocal note and accompaniment.



1. Escriu en el pentagrama els sons següents.

A musical staff in G major with notes: do (G4), mi (A4), sol (B4), re (D5), fa (E5), la (F#5), do (G5), si (A5).

2. Organitza els sons següents perquè sone l'escala de do en sentit ascendent.

A musical staff with notes: do (G4), mi (A4), sol (B4), re (D5), fa (E5), la (F#5), do (G5), si (A5). Below it is an empty musical staff for the student to write the notes in ascending order.



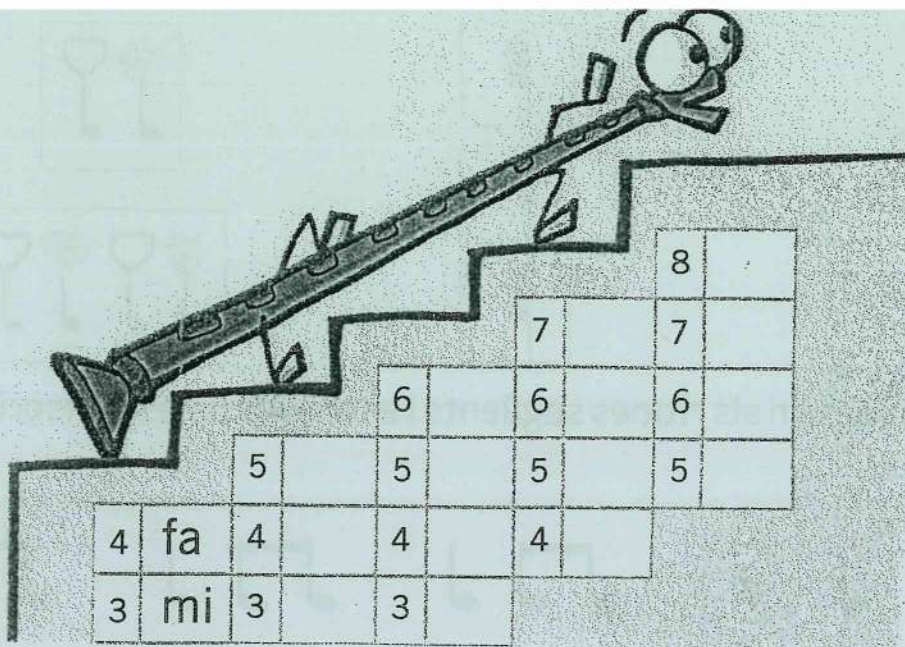

Llegim.

1

Pe-dro to-ca el vio-lín y tú to-cas el trom-bón. Con a-mor can-to al sol por-que a mis po-lli-tos les da-rá ca-lor.

2

Din, don, din, don. Le cam-pa-ne dí ma son. Do-ña Co-ti-fi-na es u-na se-ño-ra.

3

Ple-ga't, ple-ga't, pa-pe-ret, que fa-rem un par-da-let. La ga-lli-na, la pa-va-na, po-ne un co-co «pa» ma-ña-na.

4

En la to-rre a-ma-ri-lla do-bla u-na cam-pa-na. Pim, pam, re-pi-cant. Pi-ca pe-dra, pi-ca pe-dra. Pim, pam, re-pi-cant.

5

El meu car-ro's hatren-cat i es-tic dis-gus-tat. A-ra vaig a l'hor-ta tots els di-es ca-mi-nant. Que no pas-sa, que no pas-sa. Rac, rac, ca-tar-rac, que no pas-sa pel fo-ra

**CANÇÓ DESTIU (X. Guillem)**

L'es - tiu jahaar - ri - bat. L'es - co - la shaa - ca - bat. A - nem tots a la  
 Els par - da - lets con -  
 La mú - si - ca iels

mar, qui - na ca - lor que fal  
 tents, i no - sal - tres tam bé.  
 bous. a ni - ma - ran a tots. eil

**Posem les línies divisòries**

Aprende a dibujarla siguiendo con el lapicero la línea punteada:

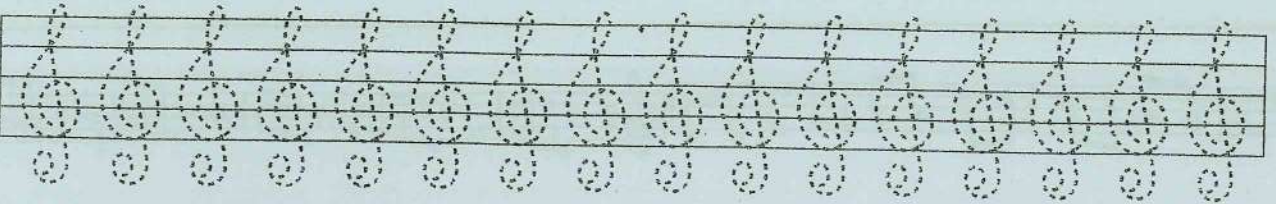
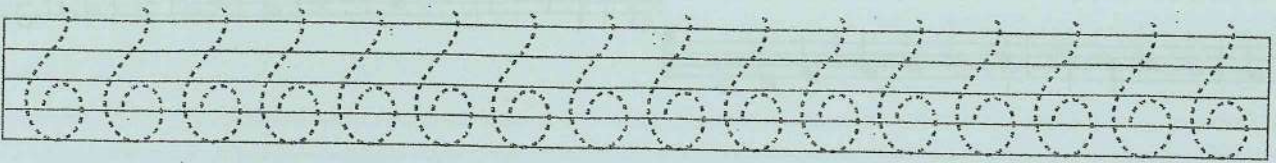
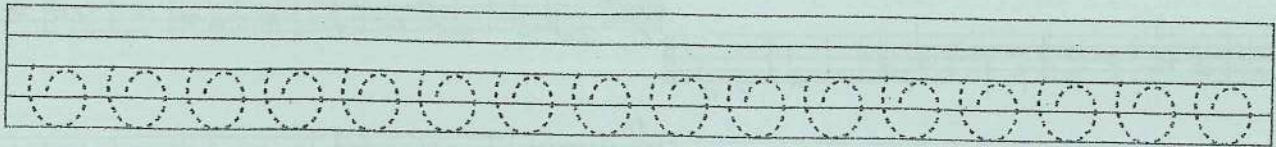

1'	do'								
7	si	7	si						
6	la	6		6	la				
		5		5		5	sol		
				4		4		4	fa
						3		3	
								2	mi
								1	

## El contrabaix

El **contrabaix** és un instrument de corda fregada.

Fa quasi dos metres d'alçada, per la qual cosa s'ha de tocar dret.

Igual que el violí i el violoncel, té **quatre cordes** i es toca amb un **arc**.



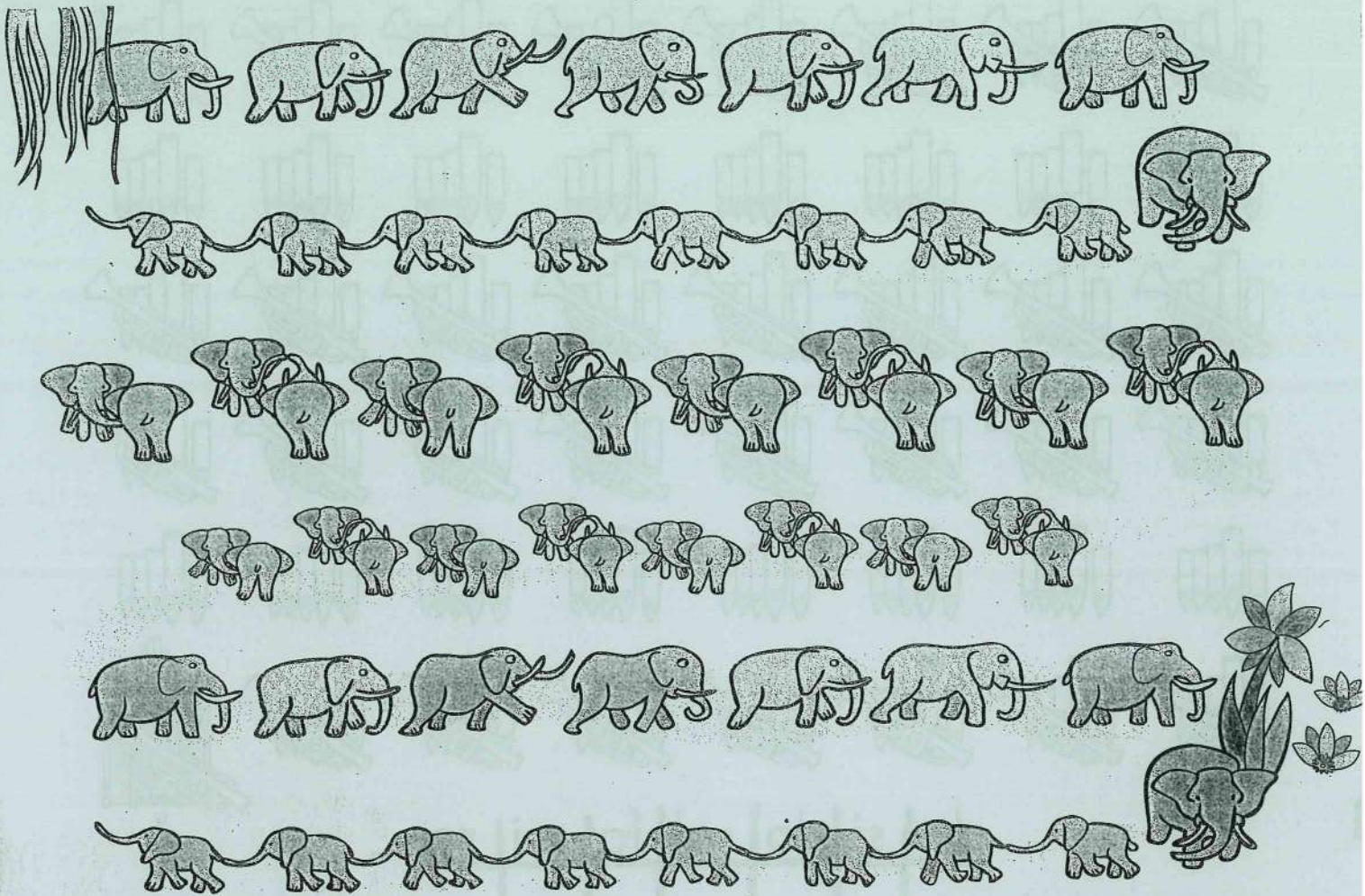

## L'orgue

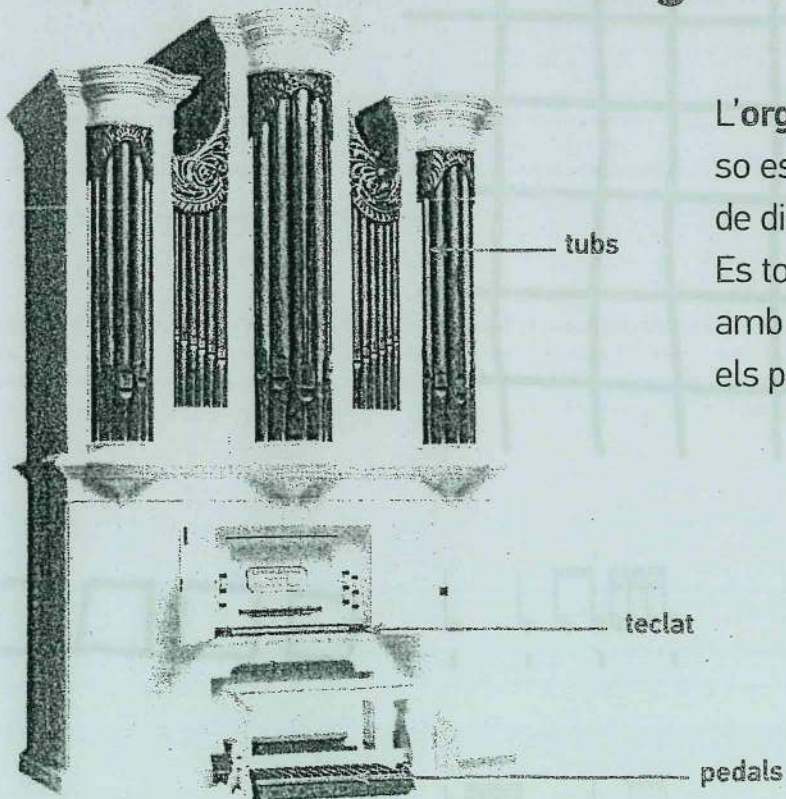

L'orgue és un instrument de vent; el so es produeix en passar l'aire per **tubs** de diferents grandàries i materials. Es toca sobre un o dos **teclats** i, a més, amb uns **pedals** que es premen amb els peus.

Escoltem «le Deum», de Marc-Antoine Charpentier.

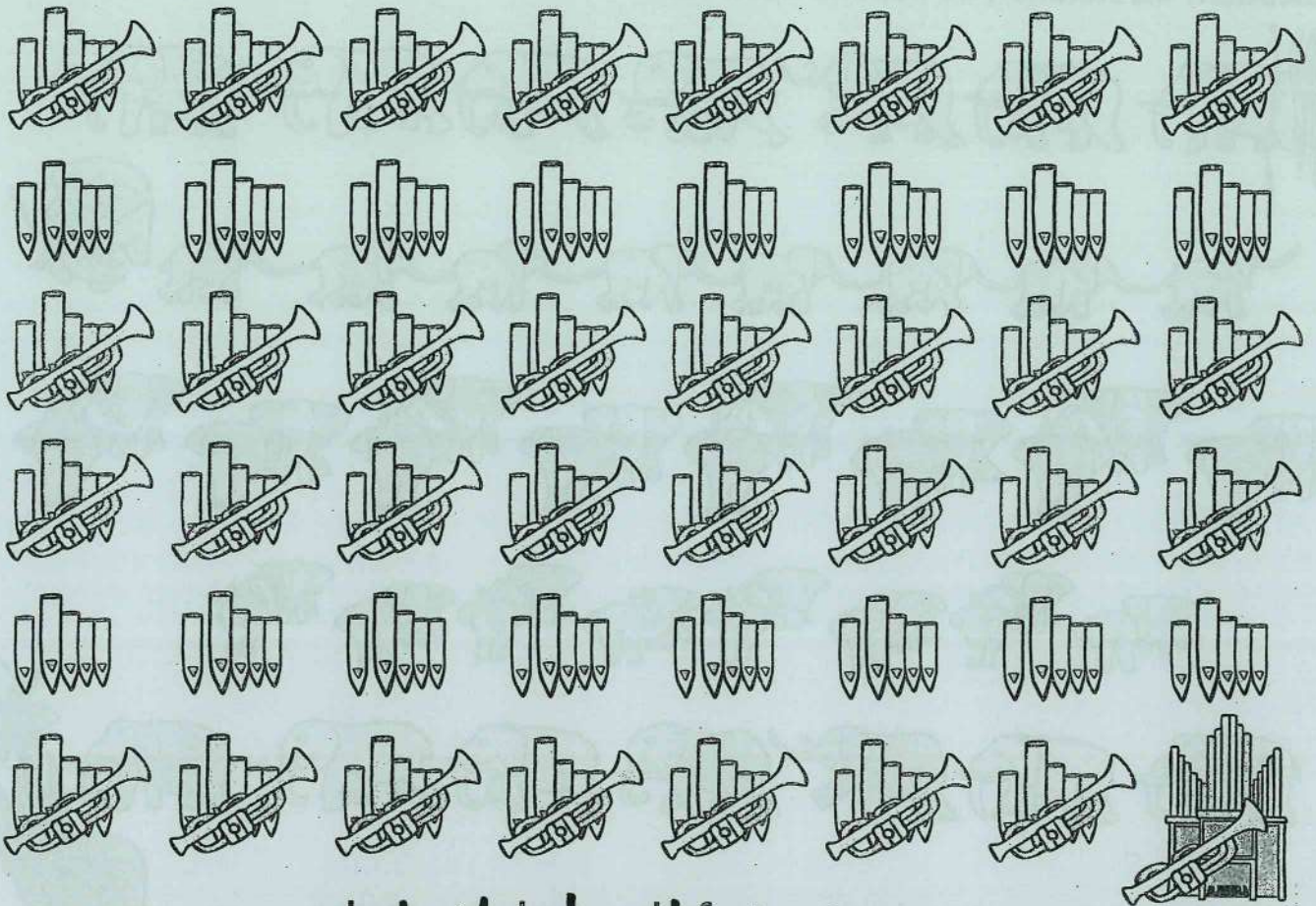

2

do	si	la	sol	fa	mi	re
si						
la						
sol						
fa						
mi						
re						
do						



Relaciona amb fletxes el ritme i la frase que li correspon.



Tin, ton, tikitikiton,



tikitikitiki, falalà!



Tin, ton, tikitikiton,

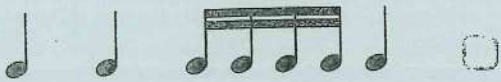

tikitikitiki, ton!

Escolta'm i fixa't en la nota que sents entre el mi i el sol. Després, escriu-ne el nombre a la casella corresponent.

a

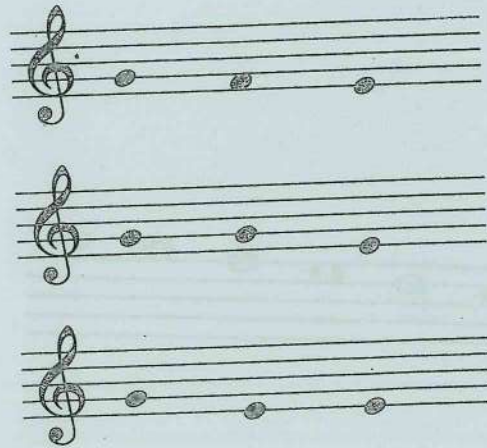

b

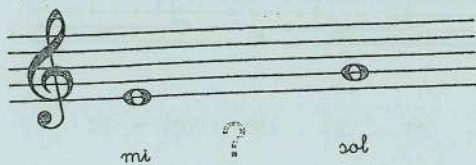

Ahora, escribe sólo el nombre de las notas que se colocan en las líneas.

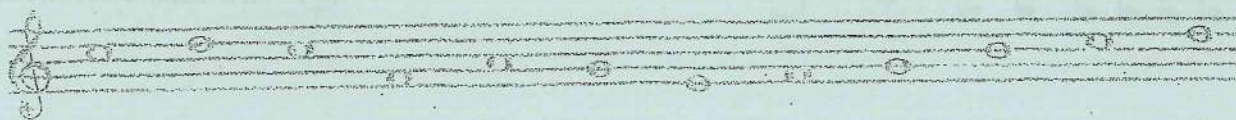

1. Dictat melòdic: En quin ordre han sonat les melodies?

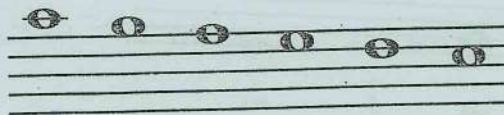
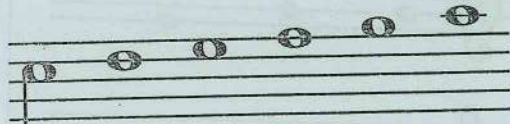
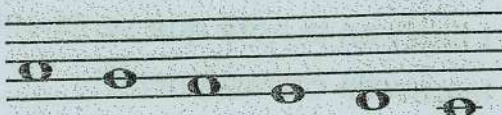
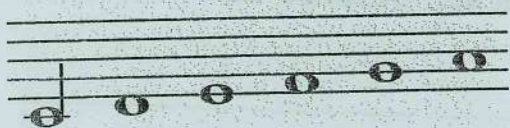

Cansat estic

*Andante*

DO SOL DO SOL7 DO SOL7

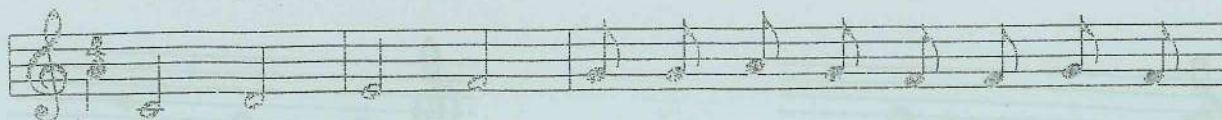

Do, re, mi, fa, sol, can - sat es - tic de sol - fe -

DC

SOL7

DO

rep. 3 vegades FI



jar i no puc jaar - ri - bar al do.

Assenyala la resposta correcta.

1 Els noms d'aquestes notes són:

- Sol, la, si
- Mi, sol, la
- Mi, sol, do



2 Aquest signe musical  $\text{☐}$  és:

- Un silenci de negra
- Un silenci de blanca
- Una corxera

Aprén i repassa els silencis:

de blanca

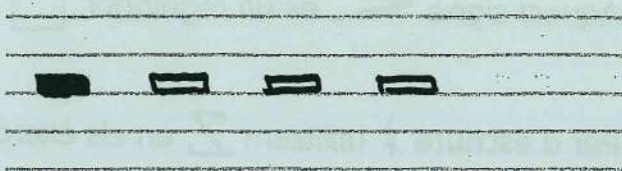

3 Quantes negres caben en cada compàs de  $\frac{2}{4}$ ?

- Dues
- Tres
- Quatre

de negra



4 Aquestes figures   reben el nom de:

- Corxeres
- Negres
- Blanques

de corxera

5 Aquest signe  s'utilitza per a:

- Repetir una nota
- Eliminar una nota

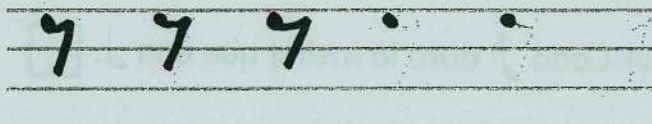

 Dibuixa la clau de Sol.

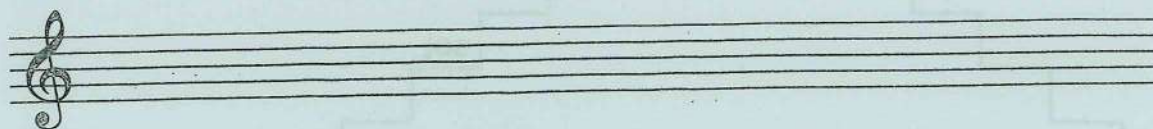
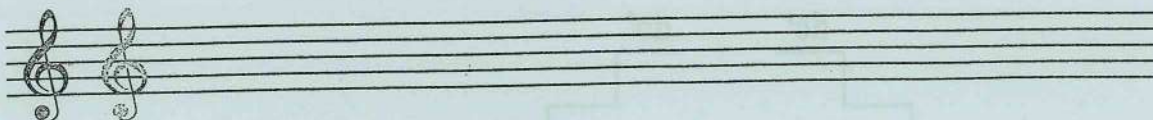



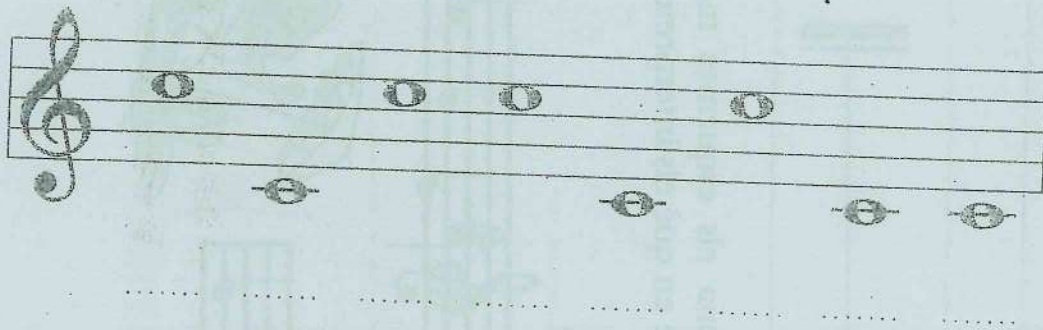
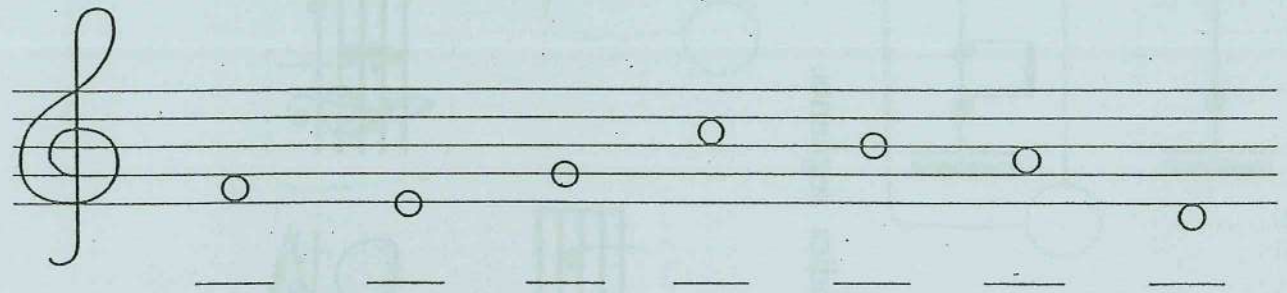
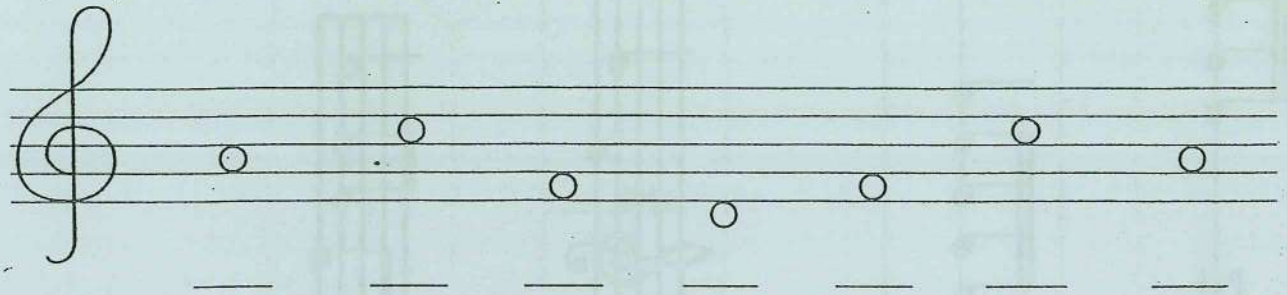
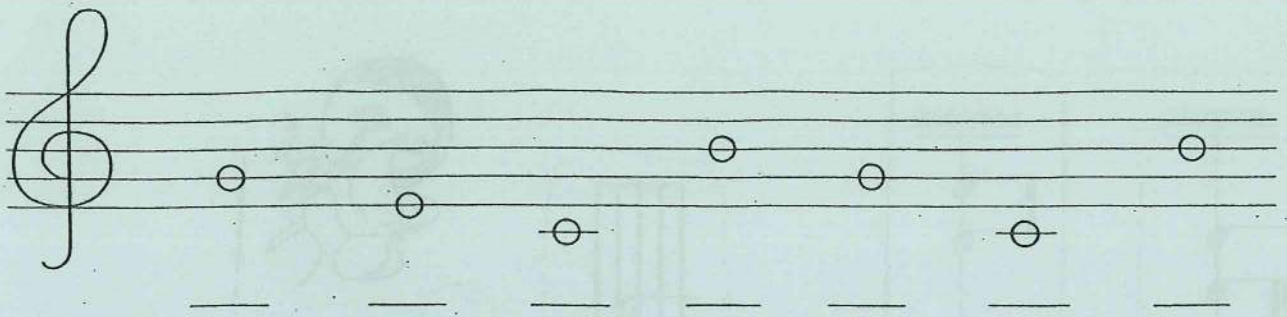

- Escribe debajo de cada sonido su nombre:

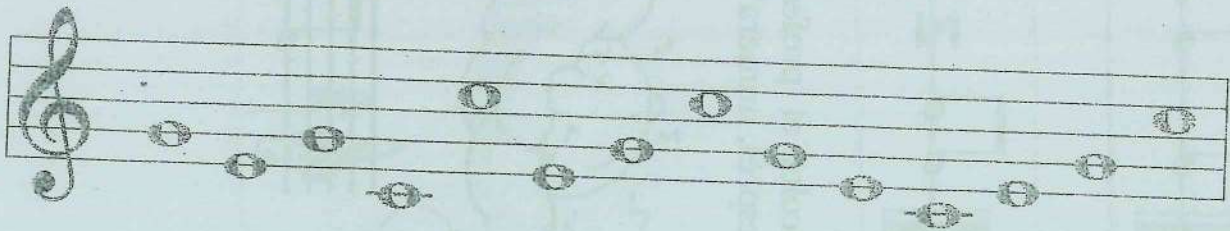

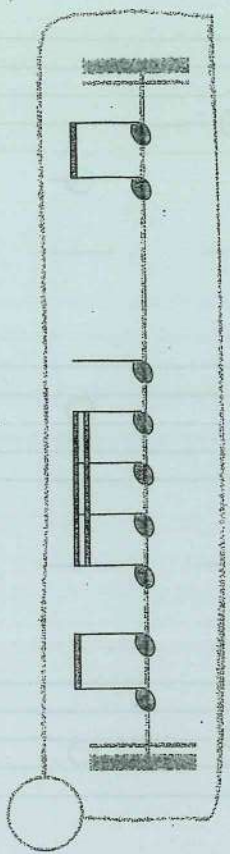
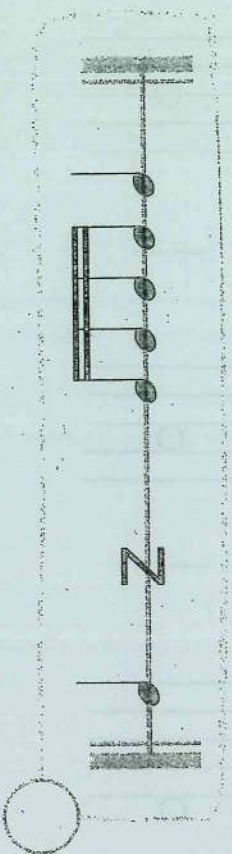
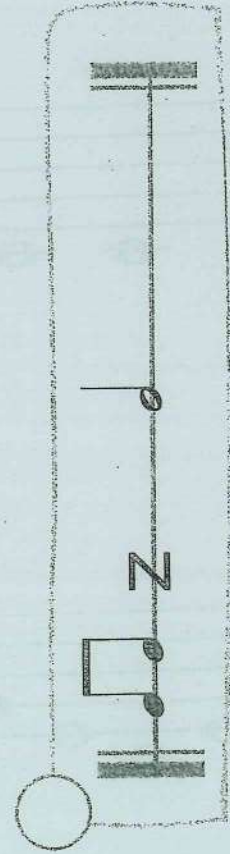
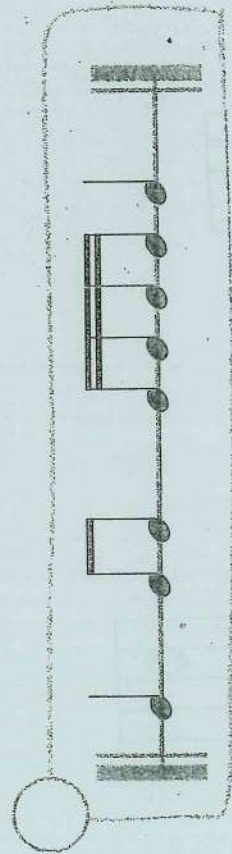

13 Escolta el professor i entona els esquemes melòdics següents.  
Després, numera'ls en l'ordre en què els interprete.

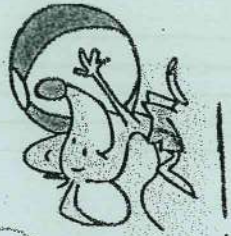
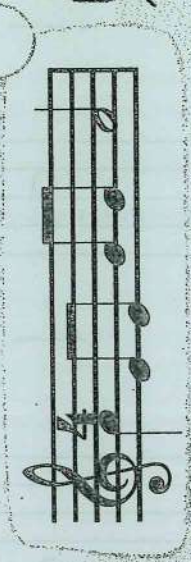
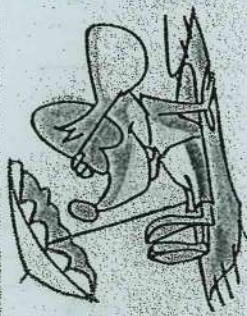
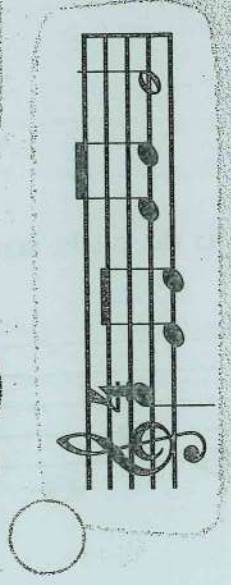
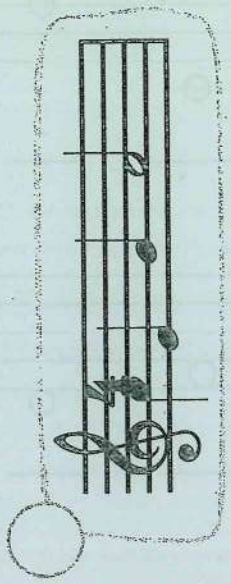

1. Compon una melodia seguint aquest codi:

1 2 3 4 5 6

A musical staff with six lines. Above the staff are numbers 1 through 6. The notes are: a white half note on the second line (1), a black quarter note on the second space (2), a black quarter note on the second space (3), a Z-shaped rest symbol (4), a black quarter note on the second space (5), a black quarter note on the second space (5), and a white half note on the first line (6).

1 1 2 3 3 4 3 4 5 4 6

A musical staff with a treble clef. Above the staff are numbers 1 1 2 3 3 4 3 4 5 4 6. The first measure contains a black quarter note on the second space (4). The rest of the staff is empty.

2 3 2 4 5 1 2 3 4 5 4 6

An empty musical staff with a treble clef. Above the staff are numbers 2 3 2 4 5 1 2 3 4 5 4 6.

- Quantes negres hi ha? -----
- Quantes rodones hi ha? -----
- Quants silencis de negra hi ha? -----
- Quantes blanques hi ha? -----
- Quantes corxeres hi ha? -----

A musical staff with a treble clef. It contains seven white half notes on the following lines: first line, second line, second space, second space, second space, second space, and first line.

A musical staff with a treble clef. It contains seven white half notes on the following lines: first line, second line, second space, second space, second space, second space, and first line.

1. Uneix amb fletxes :

Línia 1 ·	· Nota SOL	Blanca ·	· 4 temps
Línia 2 ·	· Nota SI	Rodona ·	· 2 temps
Línia 3 ·	· Nota MI	2 corxeres ·	· Mig temps
Espai 1 ·	· Nota LA	1 corxera ·	· 1 temps
Espai 2 ·	· Nota FA	Silenci negra ·	· 1 temps

2. Completa les frases :

A la línia 1 s'escriu la nota .....













A la línia 2 .....

A la línia 3 .....

A l'espai 1 .....

A l'espai 2 .....

3. Uneix amb fletxes :

	· 10 temps		· 6 temps
	· 4 temps		· 5 temps
	· 8 temps		· 4 temps
	· 6 temps		· 7 temps
	· 9 temps		· 9 temps
	· 7 temps		· 8 temps

1. Acoloreix els gerros :

VERD → 2 temps,

BLAU → 3 temps,

TARONJA → 4 temps

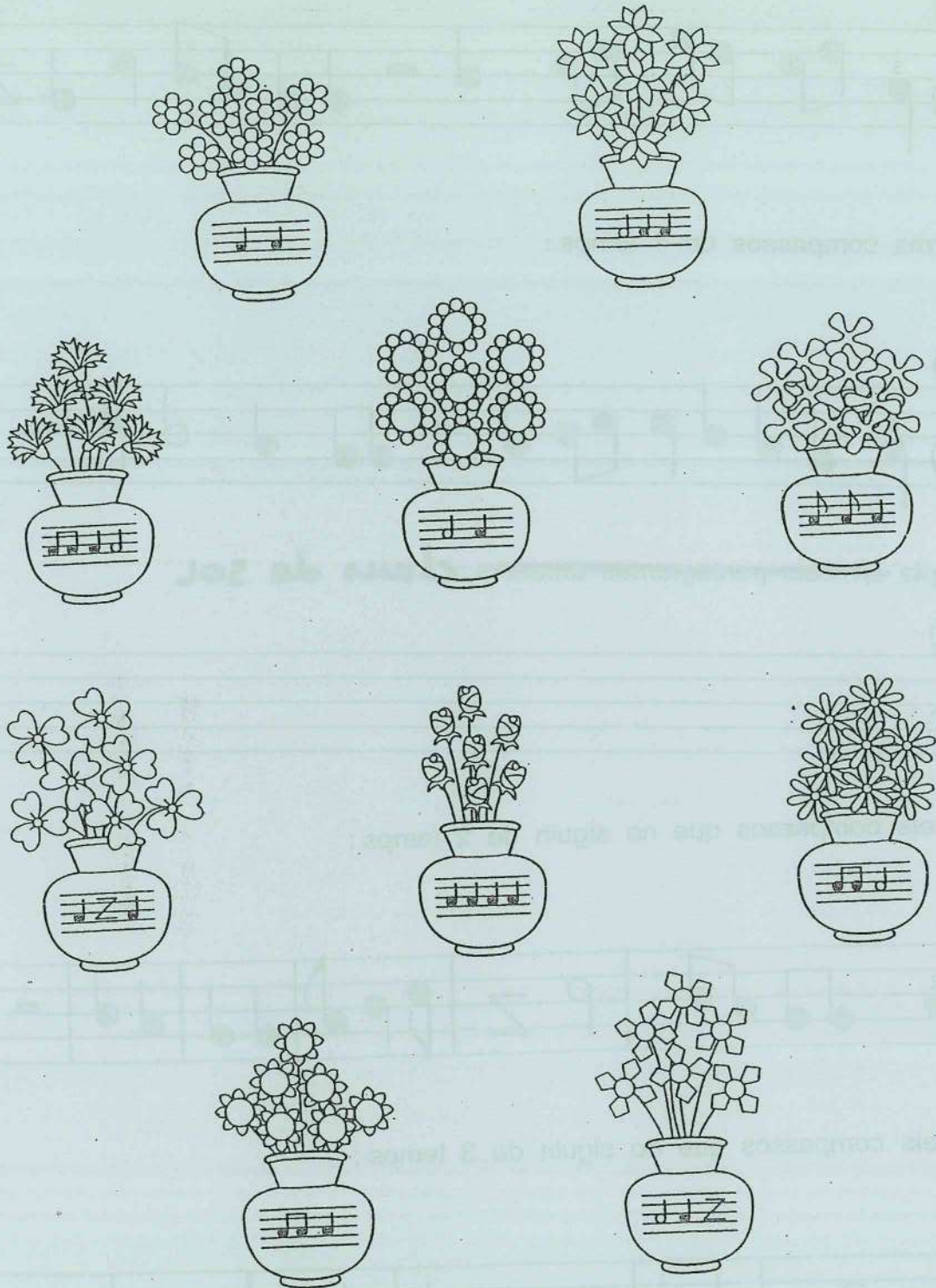

1. Forma compassos de 2 temps :

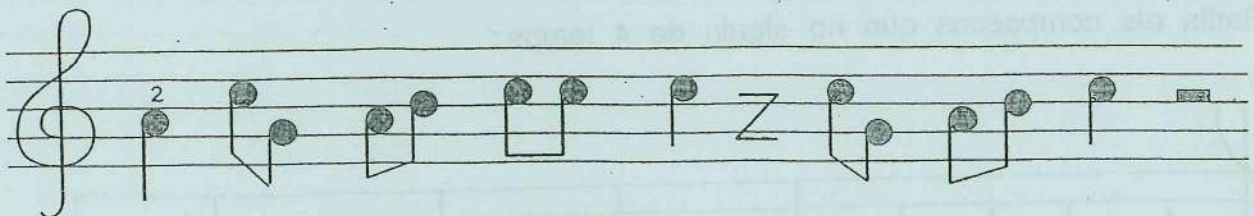

2. Forma compassos de 3 temps :

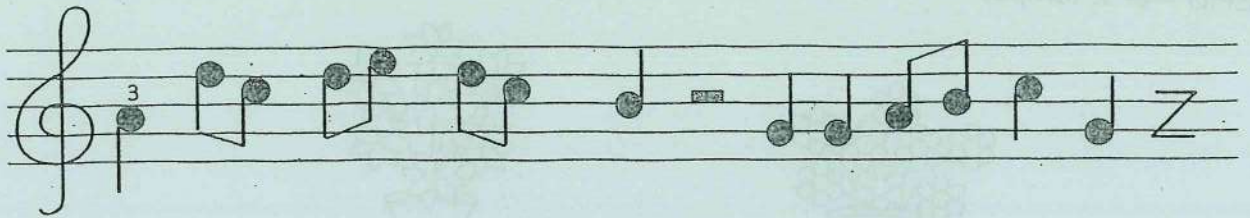

3. Forma compassos de 4 temps :

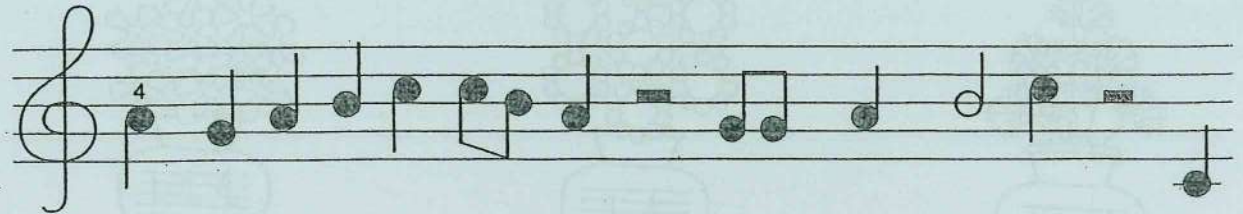

4. Copia ~~un dels pentagrammes anteriors~~ : **claus de sol**

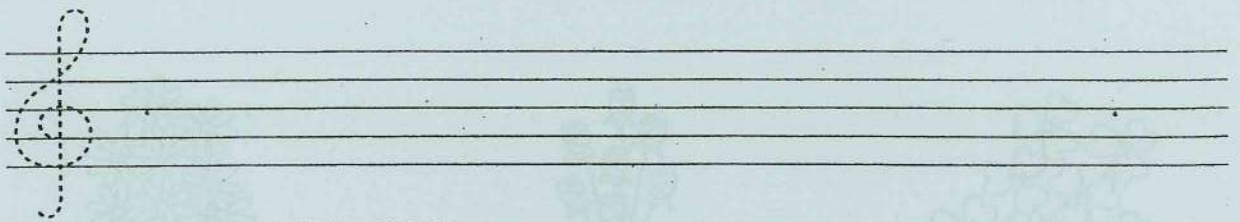

1. Ratlla els compassos que no siguin de 2 temps :

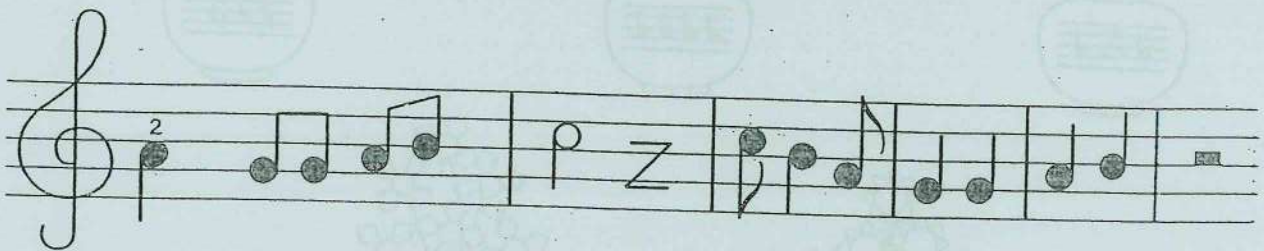

2. Ratlla els compassos que no siguin de 3 temps :

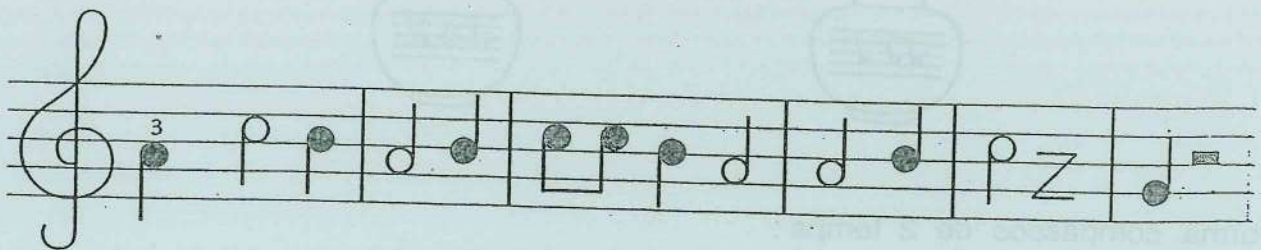

3. Ratlla els compassos que no siguin de 4 temps :



1. Fes-hi la clau de sol i la nota que s'hi indica:

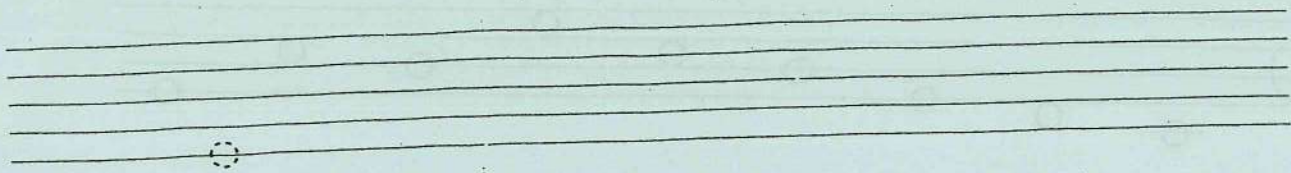

Mi      la      do'      re      sol      do

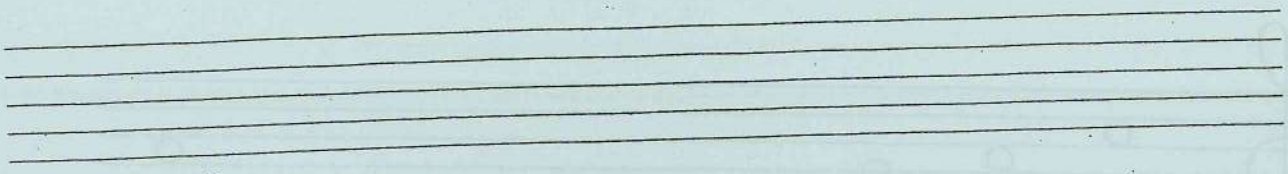

do      re      mi      sol      la      do'

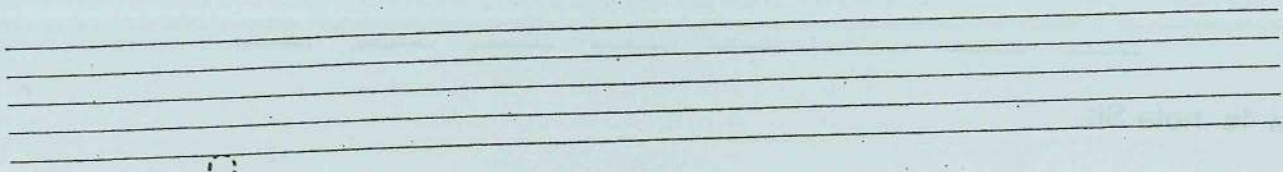

re      sol      do      la      mi      sol

2. Uneix amb fletxes:

4.



3.

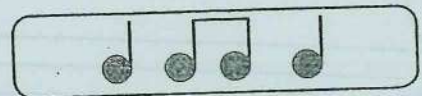
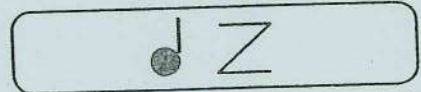

2.

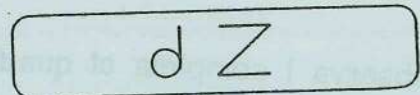
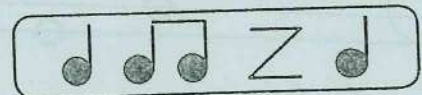

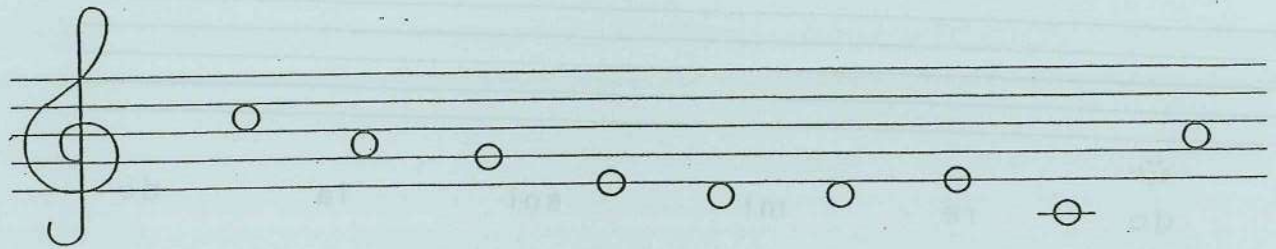
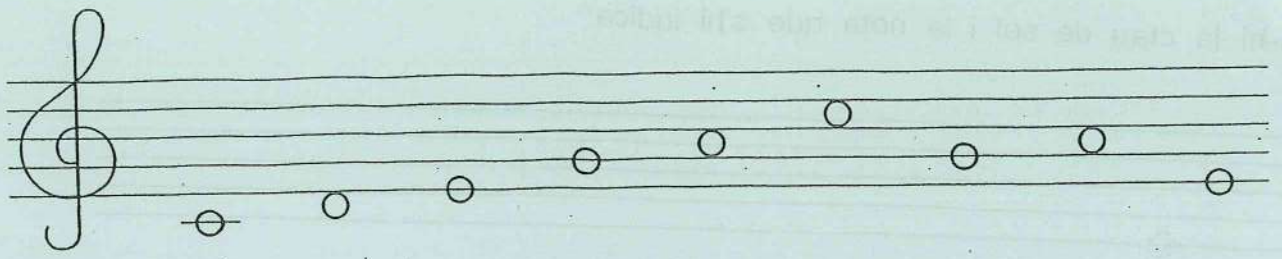

1. Ratlla la nota Si:

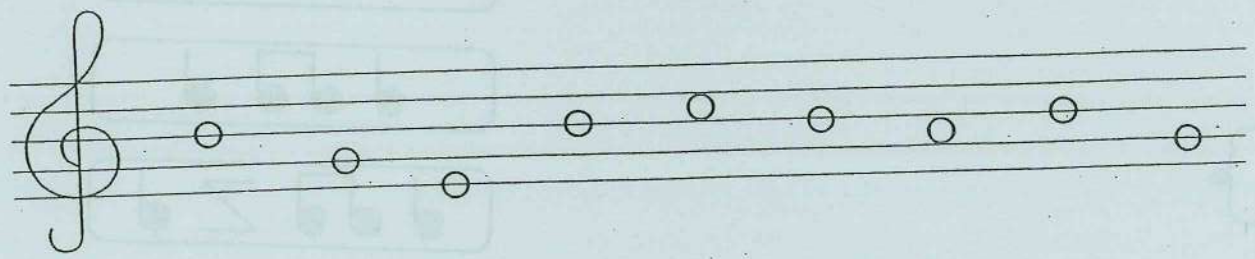
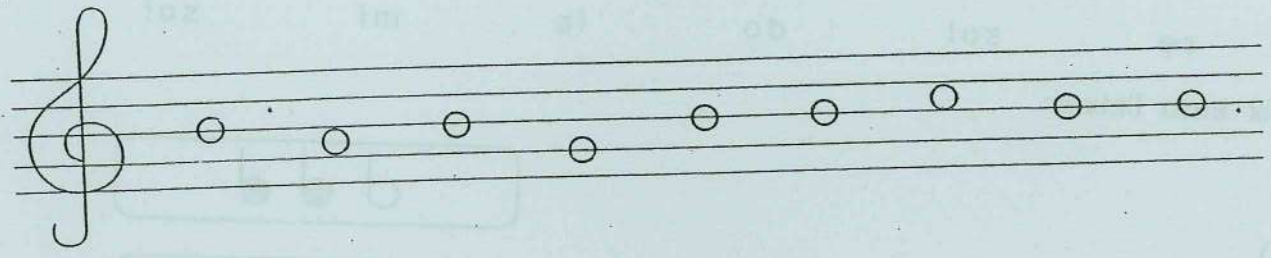

2. Observa i completa el quadre:

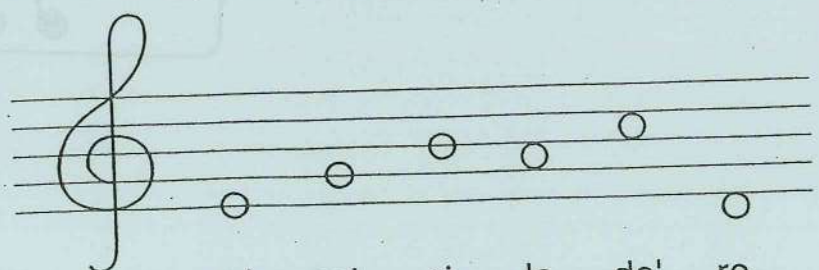
mi   sol   si   la   do'   re

Línia 1	nota _____
Línia 2	nota _____
Línia 3	nota _____

Espai 2	nota _____
Espai 3	nota _____

1. Posa-hi la nota del davant i la del darrere. Escriu-ne el nom:

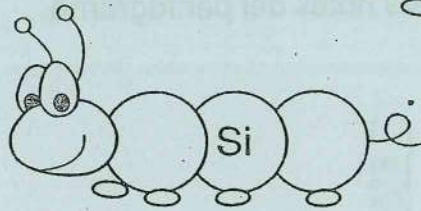
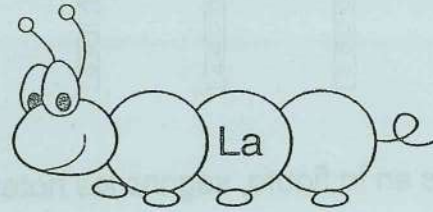
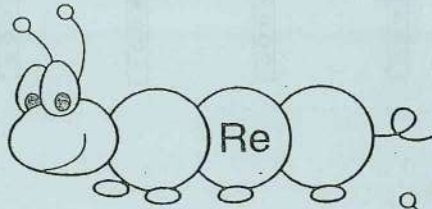
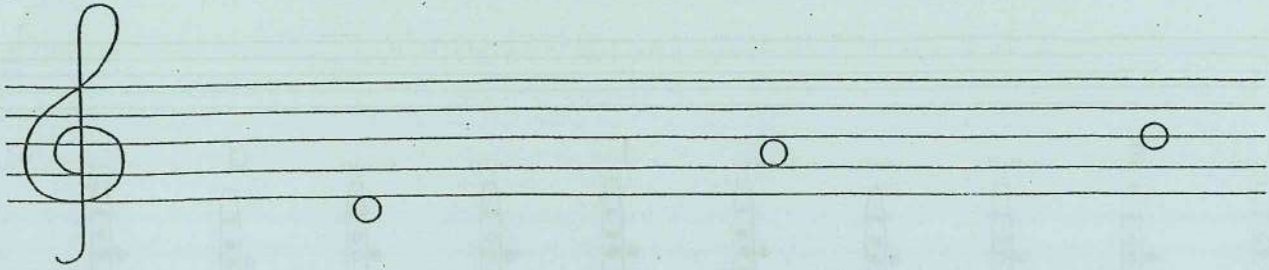

3. Escriu la nota que sonaria si tapàrem els forats pintats.

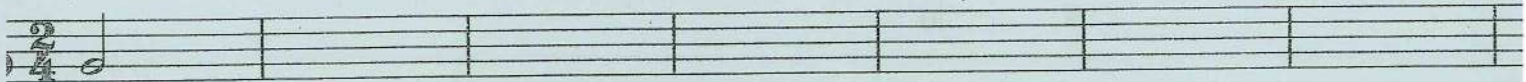
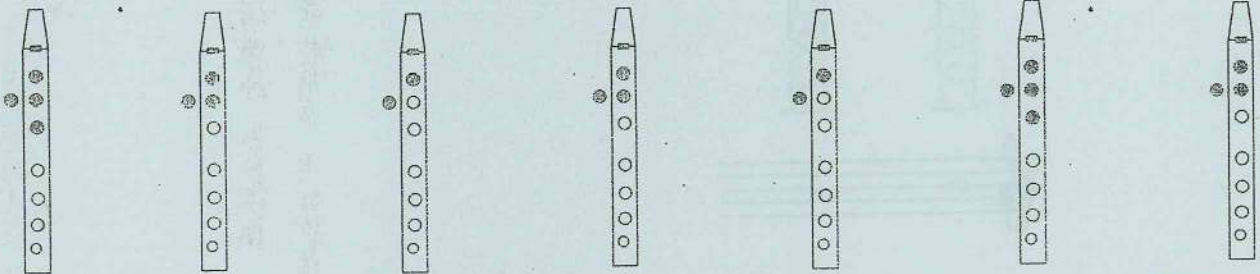

sol

Dibuixa al pentagrama la nota que fa cada flauta.



Sol

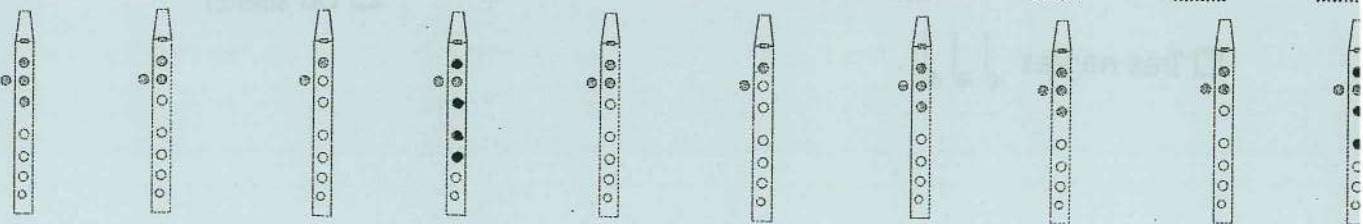



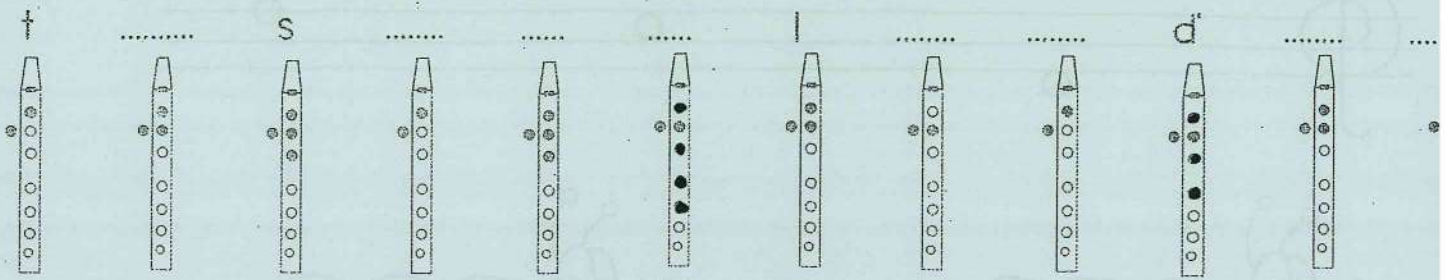

Indica al pentagrama les notes que fan les flautes.

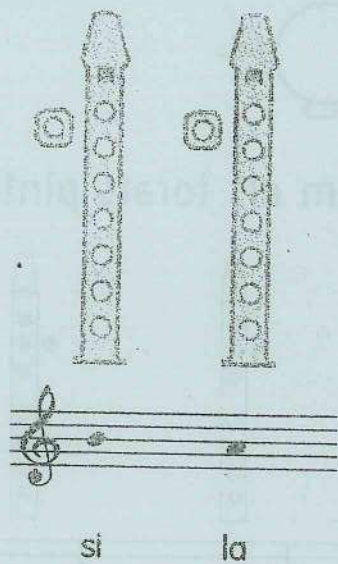

5 Pinta els forats en la flauta, segons les notes del pentagrama.



3 La figura de blanca  dura el mateix temps que:

- Una negra 
- Dues negres 
- Tres negres 

6 Què és aquest signe  ?

- Una nota
- Una lligadura
- Un silenci

4 Observa la imatge. Si tapes aquests forats en la flauta, sona:



- Sol
- La
- Si

5 Escriu davall del pentagrama el nom de cada nota. Després, encercla la flauta que no representa la nota correcta.

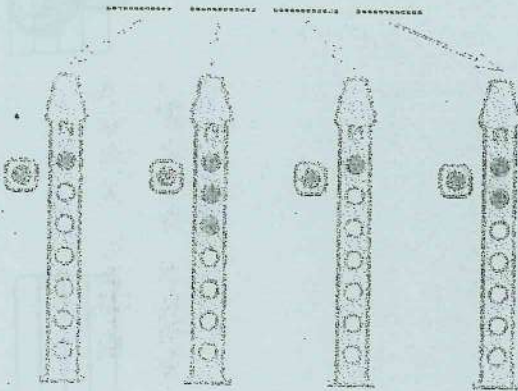

Escriu el nom de la nota representada en la flauta.

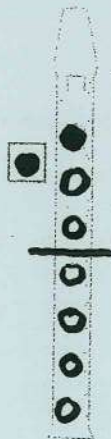

És la nota .....

S'ha de tocar amb la mà .....

Repassa les claus de sol i completa les que falten.

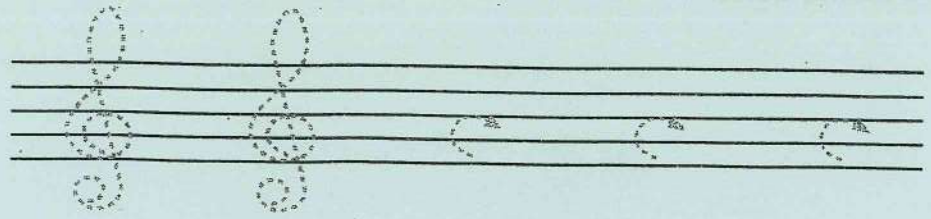

3  Acoloreix els forats que han de tapar-se perquè sonen les notes indicades a baix de cada flauta.

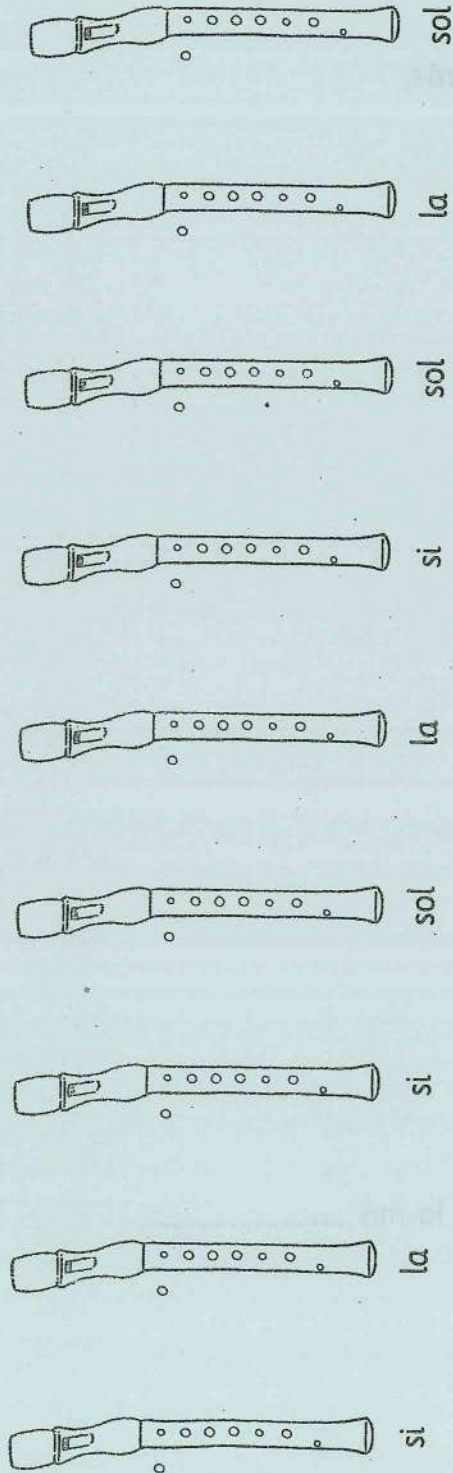

4  Uneix amb fletxes cada flauta amb la seua nota.

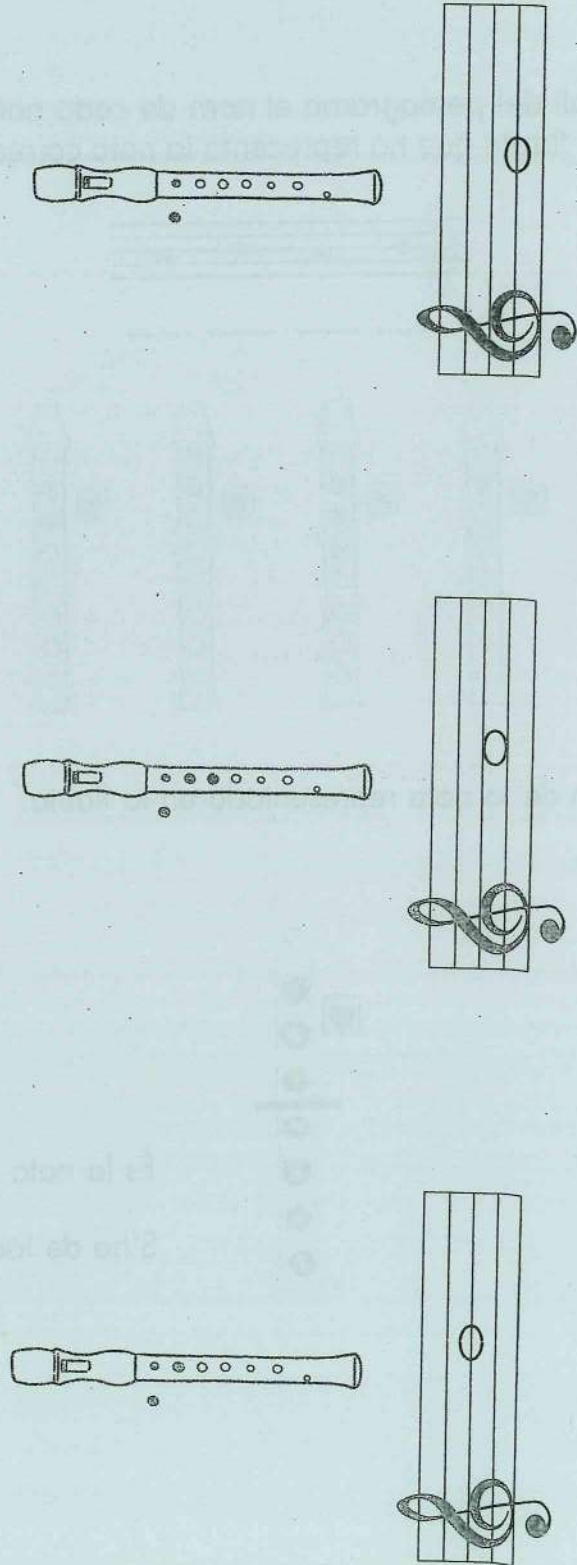

2 Dibuixa al pentagrama les notes representades en aquestes flautes.

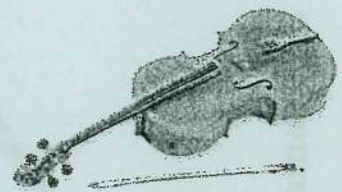
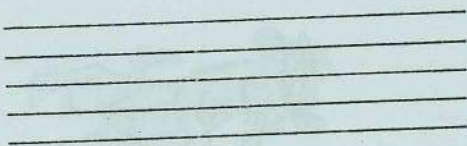
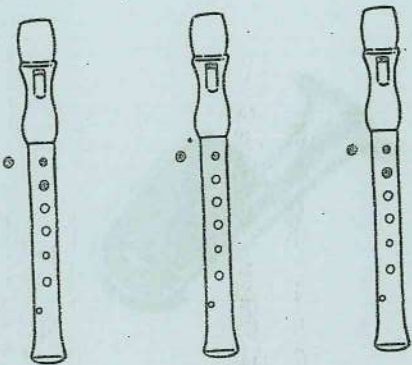
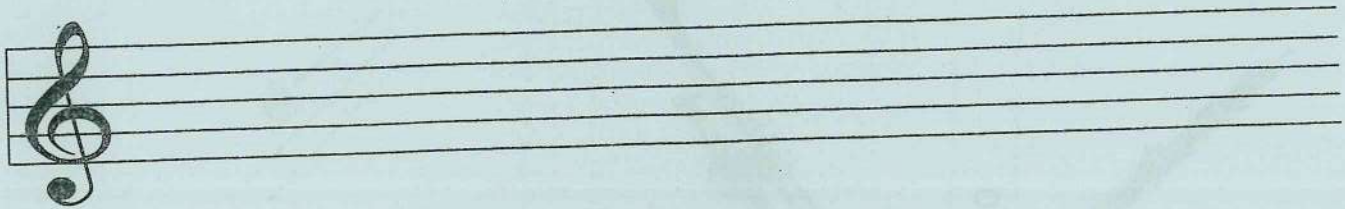
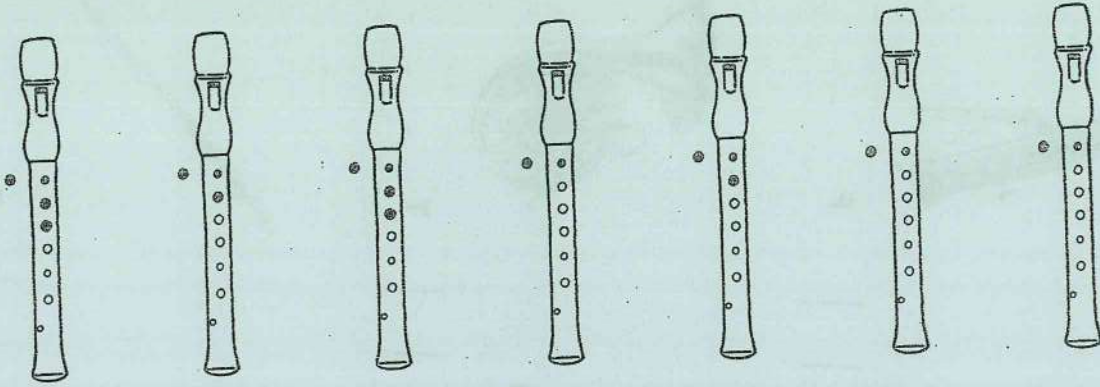

V \_\_\_\_\_

V \_\_\_\_\_

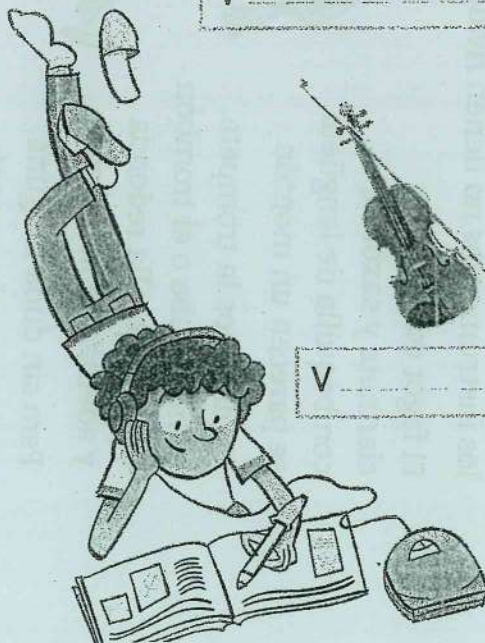

V \_\_\_\_\_

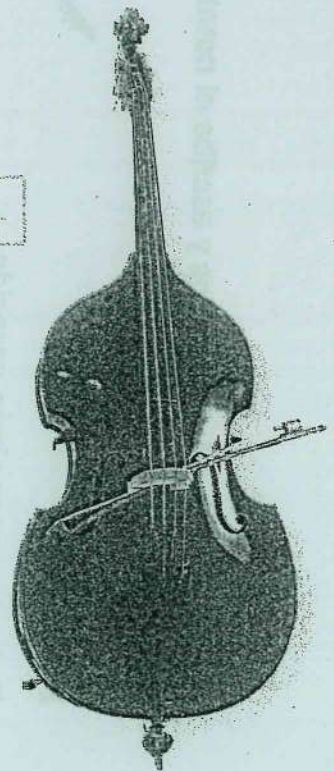

C \_\_\_\_\_

Aprende la canción *Parecidos* y escribe el nombre de los instrumentos que suenan o que se nombran.

### Parecidos

Todos tenemos algún parecido con la familia donde hemos nacido. En cuanto a familias, con similares, los instrumentos no tienen rivales.

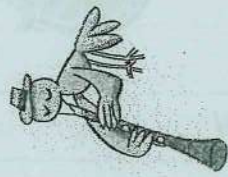

El fagot con el oboe, clarinete y saxofón, con boquilla de lengüeta, se parecen un montón.



No digamos la trompeta, trompa, tuba o el trombón tienen boquilla redonda y además de metal son.

Pero sin duda ninguna, del mayor al pequeño, son los que más se parecen: la familia del violín.

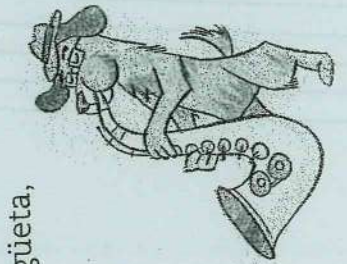

Y aunque no tenga lengüeta, como oboe o saxofón, es de la misma familia con muchísima razón.

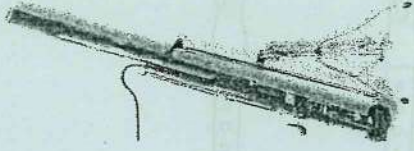

F

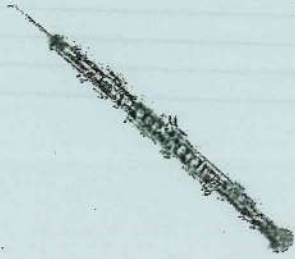

O



C

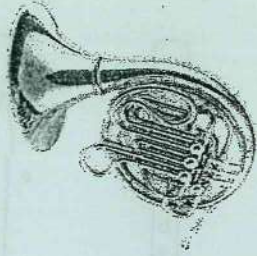

T



T

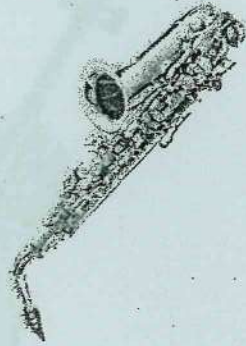

S

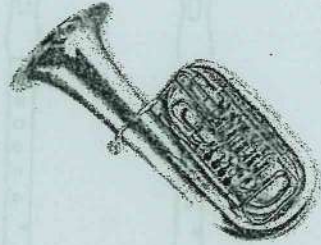

T

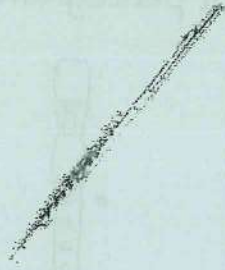

F



T

... seguir el orden de audición. Luego, escribe sus nombres.

Cuerda. El sonido se produce al frotar las cuerdas con un arco, al pulsarlas con los dedos o con una púa, o al golpearlas.



V



V

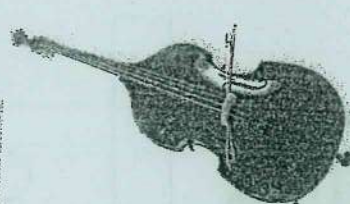

C

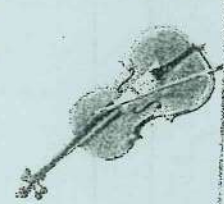

V

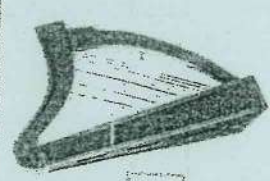

A



G

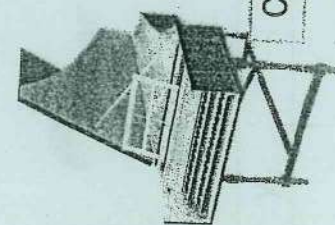

Clavicémbalo

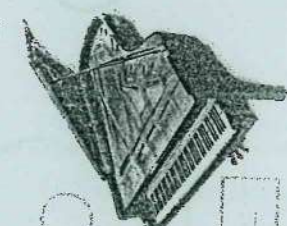

P

Viento. El sonido se produce cuando el músico sopla por una boquilla e introduce aire que vibra dentro del tubo.

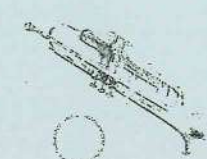

S

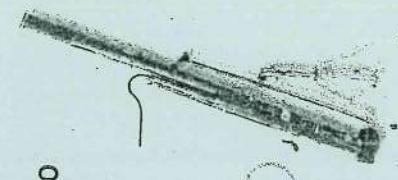

F g t



T



Tr mp



O



C

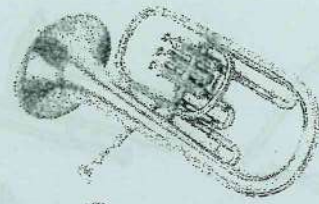

T



F travesera

corda

vent

percussió

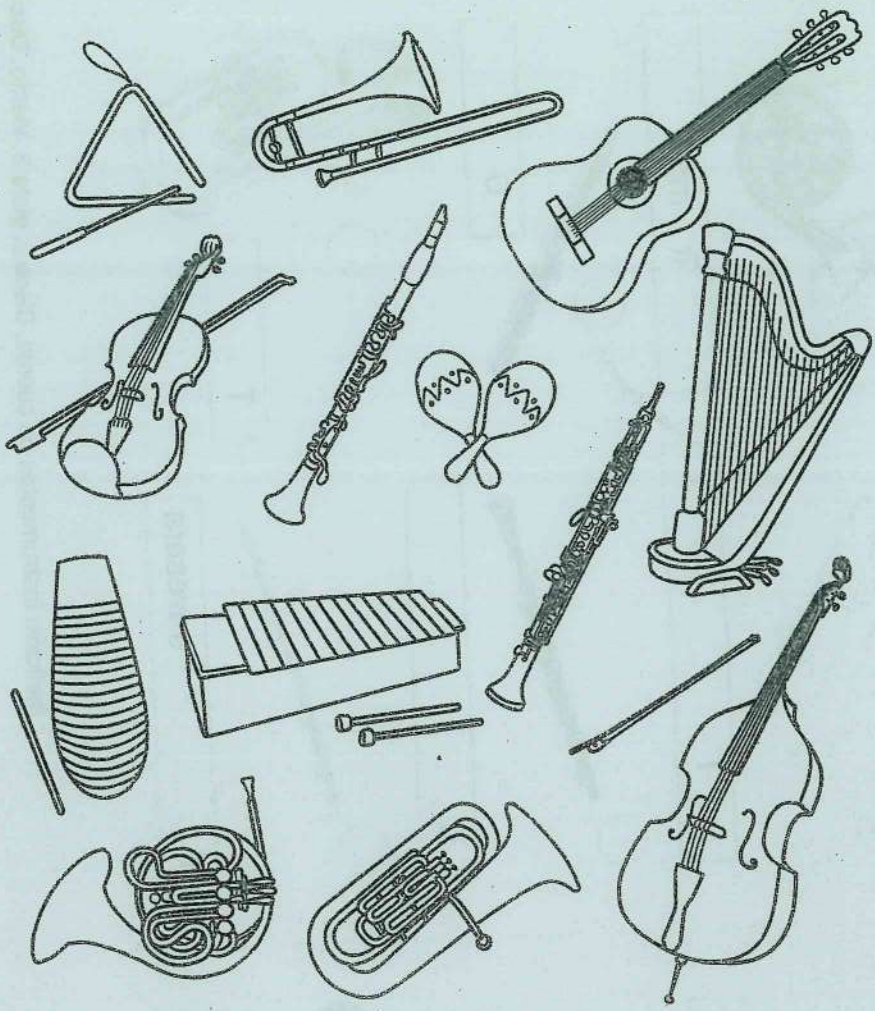

M



P

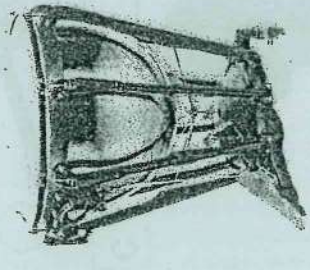

T



C

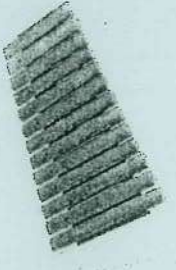

X



M



T



T

*p* Bu - fa amb sua - vi - tat du - es no - tes si i la.

Si, si, si, la, la, la, la, la, la, si, si, si, si, la, la, si.

*Taula de digitacions*

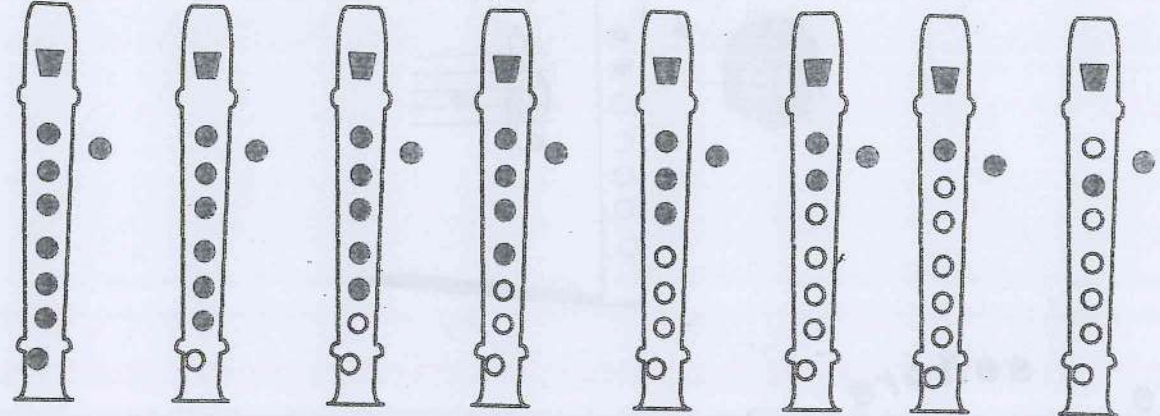

do re mi fa sol la si do'

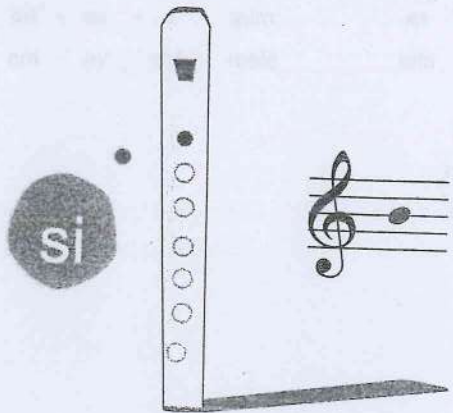

si

*Melodia del si*

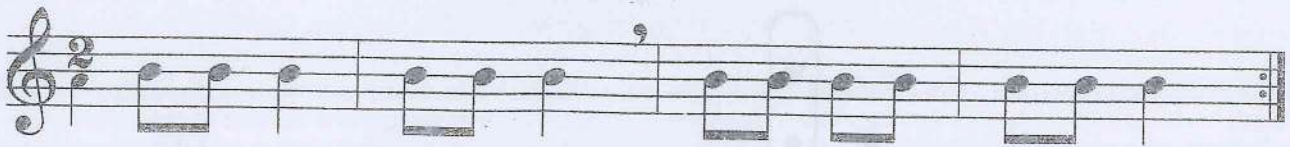

*Din, din, don*

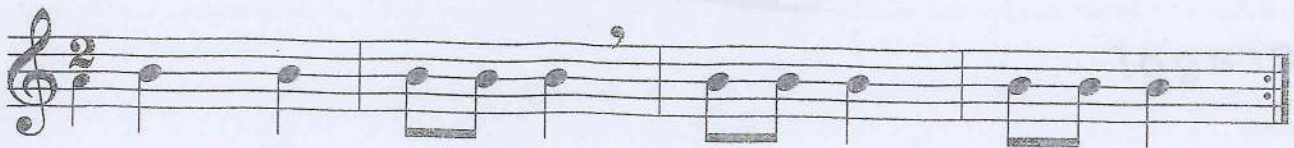

la

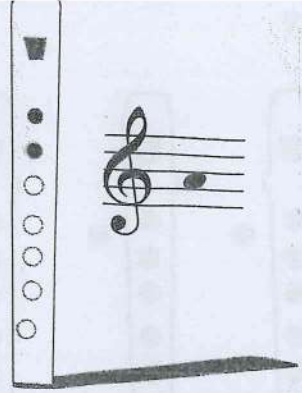

# Una señora



U - na se - ño - ra      muy a - se - ño - ra - da  
Aun - que va\_en co - che      siem - pre va mo - ja - da.

# Doña Cotifina



Do - ña Co - ti - fi - na      es u - na se - ño - ra,  
que se cons - ti - pa - ba      ca - da - me - dia ho - ra.

## FLUTESON 1,2,3,5

sol

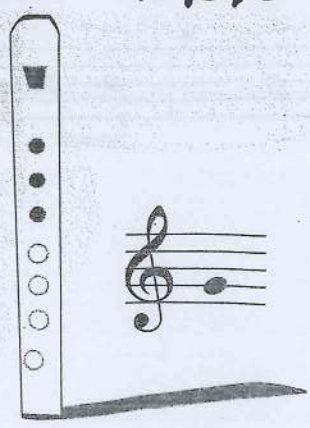

# Caragol

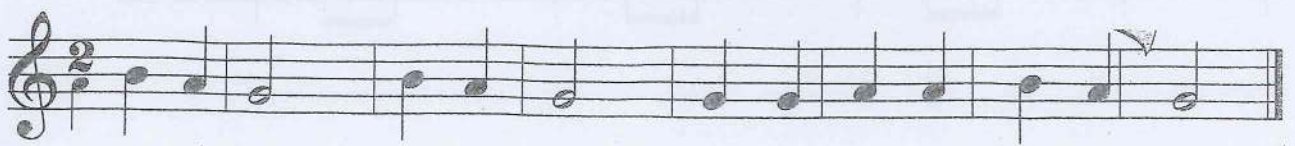

Ca - ra - gol      ca - ra - gol,      trau les ba - nyes que ix el sol.

*s-l-t*

U - na pu - ça\_em - pre - nya\_un gat  
fent - li pes - si - go - lles din - tre del seu nas.

*2. Canon al unísono*

*Galop*

*Equip Stringa*

*s-t-s*

**FLUTESON 7, 8, 9**

mi



Sol, sol mi

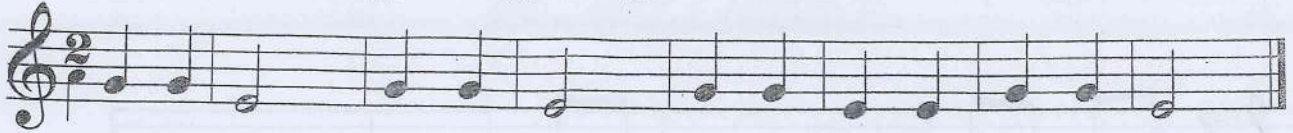

### 1. Pavo, pavo con arroz

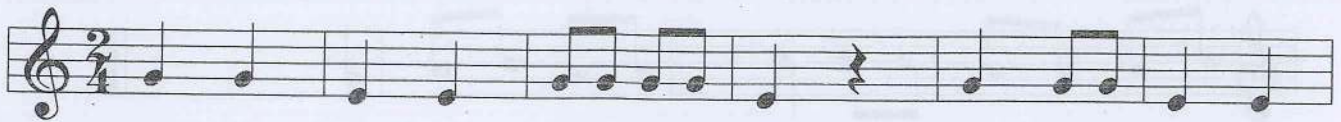

Pa - vo, pa - vo, pa-vo con a - rroz. Si no lo co - mes,



me lo co-mo yo, ca-ba - lli-to de la mar te que-das-te sin la - var.

### Aserrín aserrán

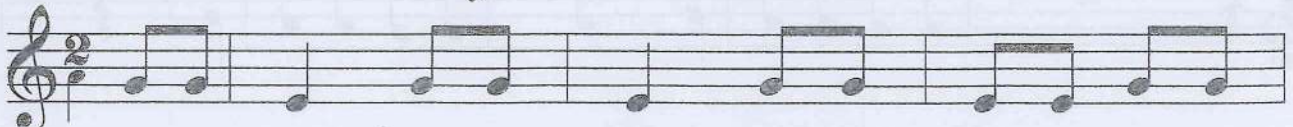

A - se - rrín, a - se - rrán, los ma - de - ros de San

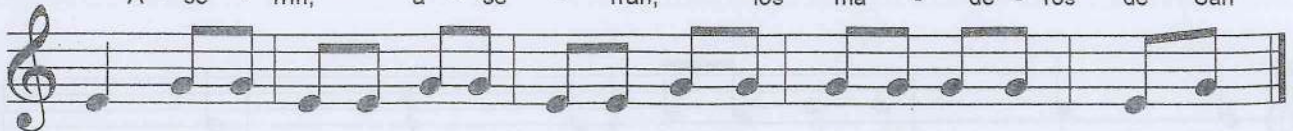

Juan, el pa - la - cio y la co - ci - na, ¿cuán - tos de - dos ten-go en - ci - ma?

### El camí de Sant Joan

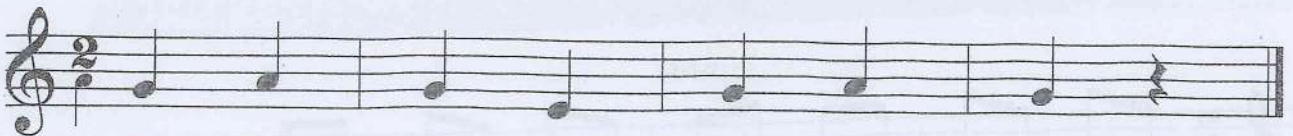

Uns que vé - nen al - tres van  
pel ca - mí de Sant Jo - an

# Margarita

U - na dos tres y cua - tro  
 Mar - ga - ri - ta tie - ne un ga - to.

Es fica les notes al despertador

Popular

Es fi - ca les bo - tes el des - per - ta - dor,  
 Ja to - ca la u - na, ja to - quen les dos,  
 es fi - ca les bo - tes per a - nar mi - llor.  
 ja to - quen les tres en el des - per - ta - dor.

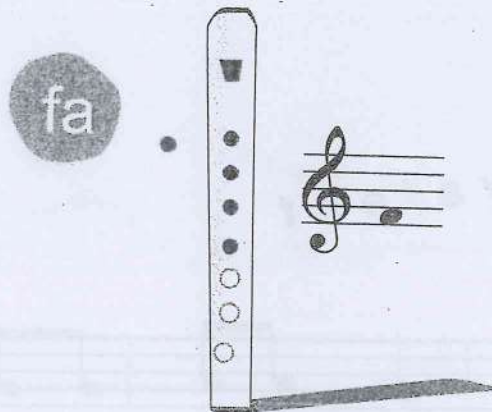

## 3. Si la barqueta...

Si la bar - que - ta es tom - ba xi - ca no tin - gues por,  
 Al - ça la cor - da en l'ai re i can - ta u - na can - çó.

claves

Car. All

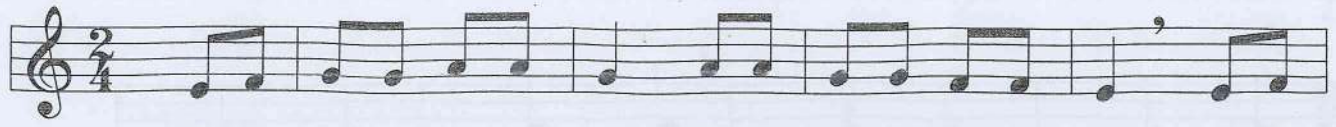

Al mi - la - no ¿qué le dan? Ce - bo - lli - tas con el pan, por la



no - che pan y pe - ra, por el día pe - ra y pan.

### 2. Peix, peixet



Peix pei - xet, de la ca - nya de la ca - nya,



peix pei - xet de la ca - nya al sar - ro - net.

### El ruquet valent

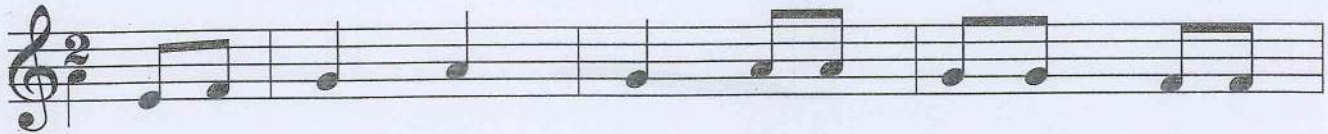

El ru - quet va - lent por - ta car - ga por - ta

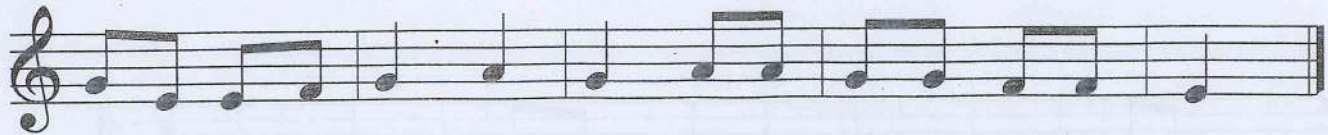

car - ga el ru - quet va - lent por - ta car - ga i no la sent