

Organizing Your Chemistry Laboratory Notebook



Developed By:
Gabriel Chavez
(Learning Assistant)

SSC Coordinator/Activity Director: **Lilit Haroyan**

SSC Advisor/Faculty: **Dr. Mike Fenton**

Technical Support: **Hagop Hadjinian**

Funded by: Title V HSI ISSA, Department of Education

Sources: Google, Chemistry Lab Manual Provided by Physical Science Department

Lab Notebook will Begin with a Title Page

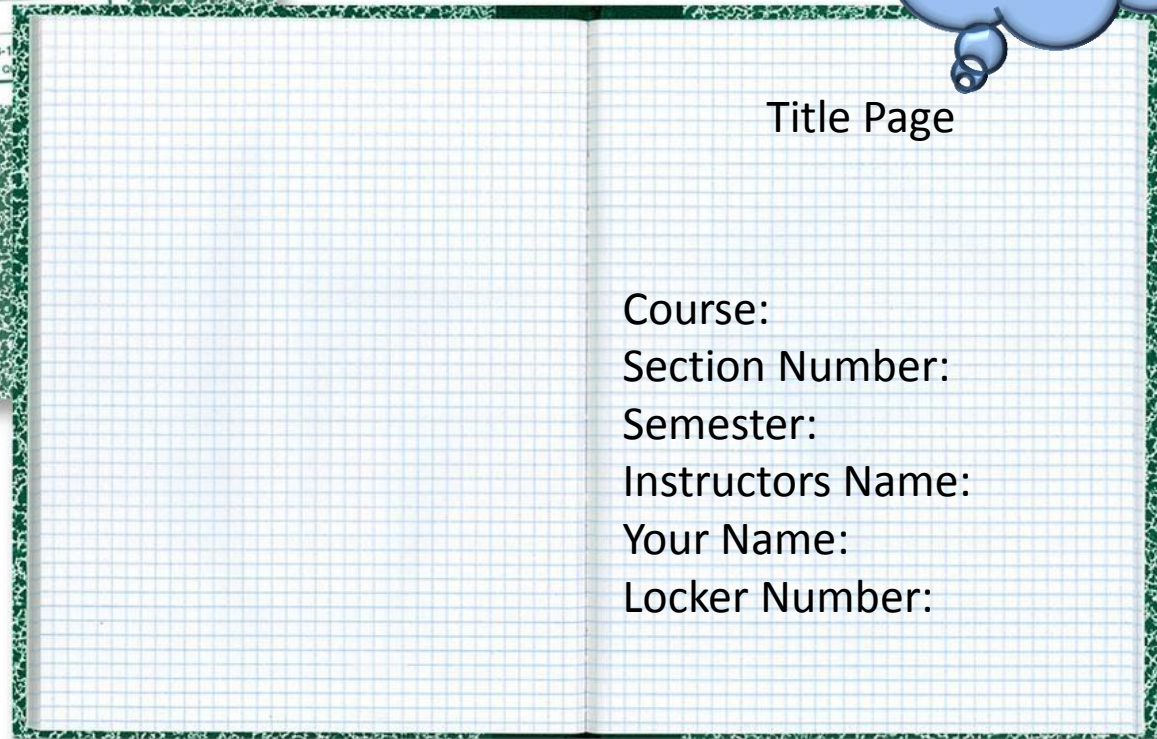

2nd Page is the Index for the Lab

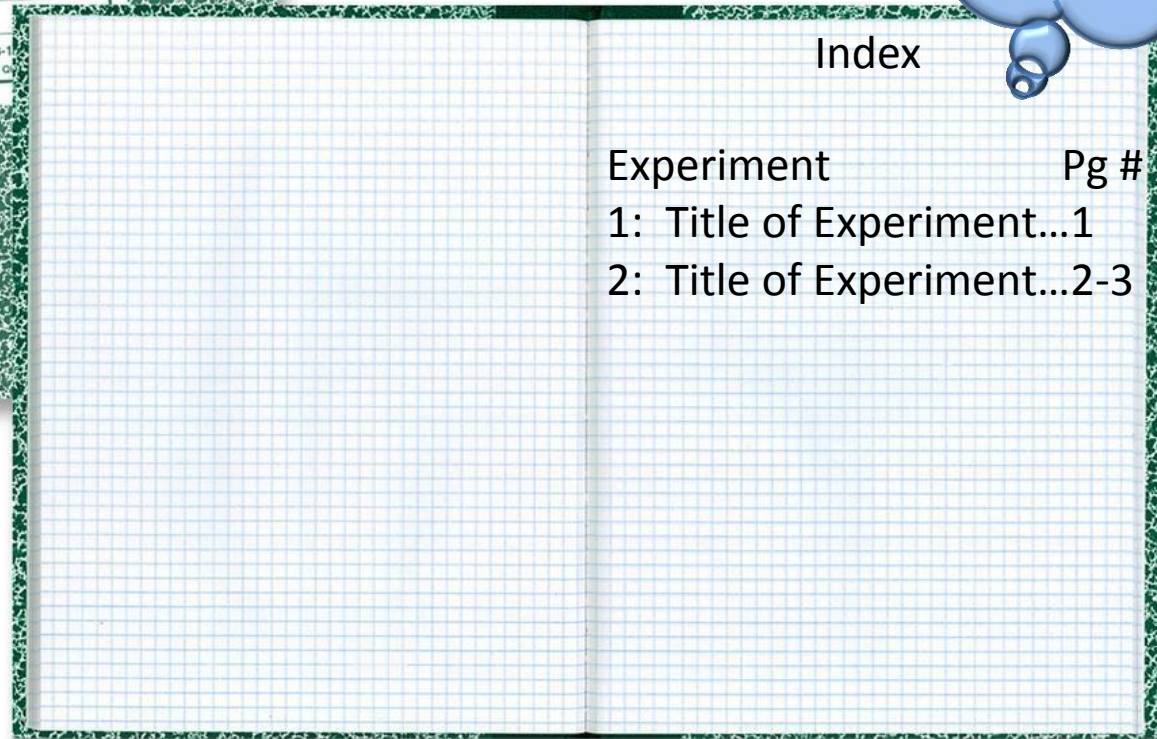

Copy all the index as it is in your Lab Manual

3rd Page Bibliography

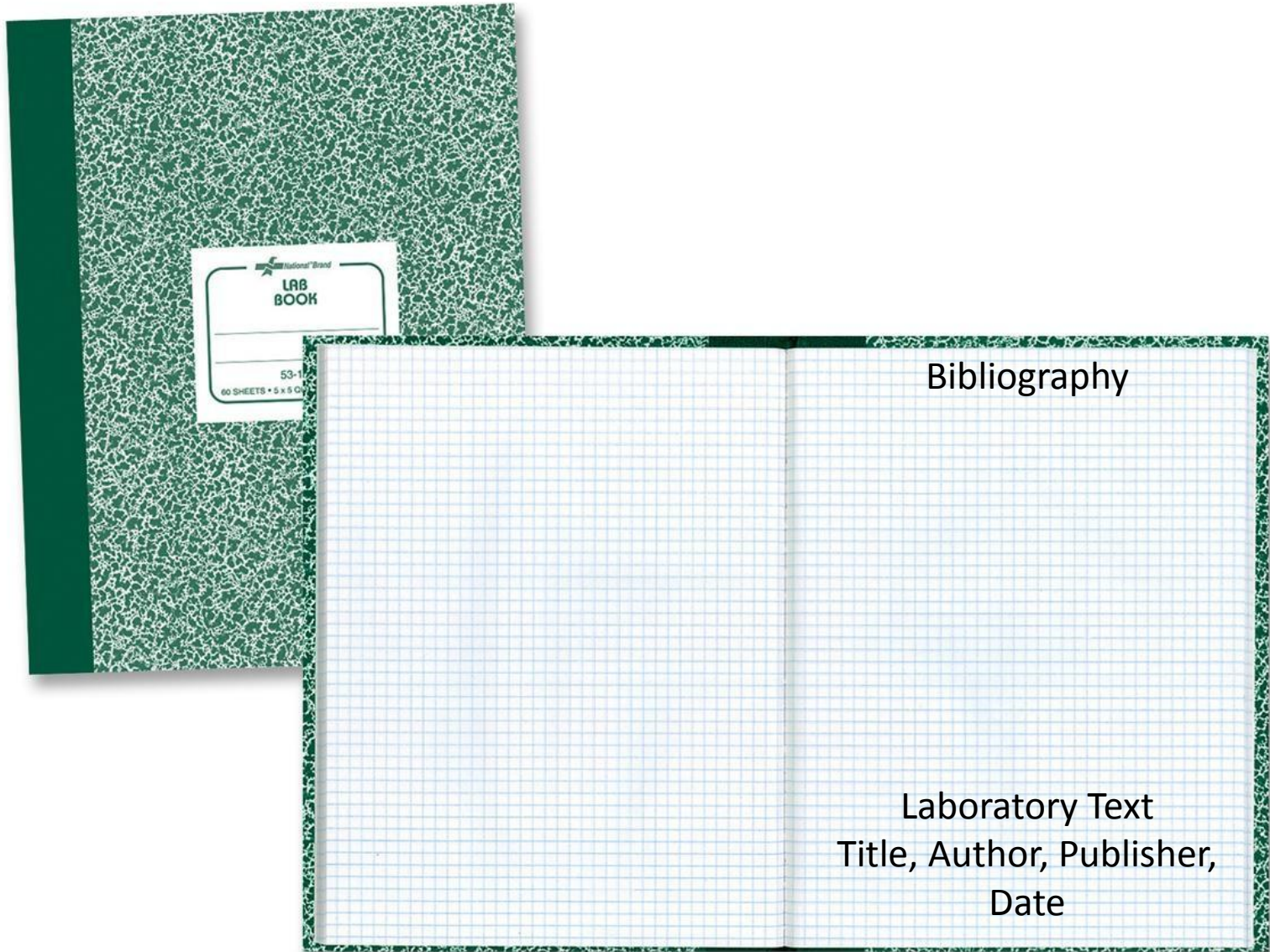

This will be your first Lab Recording



After this page the rest of the experiments will have the same structure.

Make sure you date every experiment.

Page #
Date

Title:

Purpose:

Procedure:

Data / Observations:

Results:

Conclusion:

Don't forget to include you **UNKNOWN**S

Always Remember

Left Side
Designed for
Notes and
Calculations

Right Side
Designed for Lab
Experiment
Procedures and
Data

Important

Always write down the tools used to perform the experiment(ex. Glassware)

If you have a hard time remembering the tools you should draw them.

Important

Write down a summarized procedure to help you during your lab exams.

Once you receive your graded lab, you should go into your lab notebook and make the appropriate corrections.

Learn the Glassware List

There will be more items listed on your inventory. Make sure to include them.

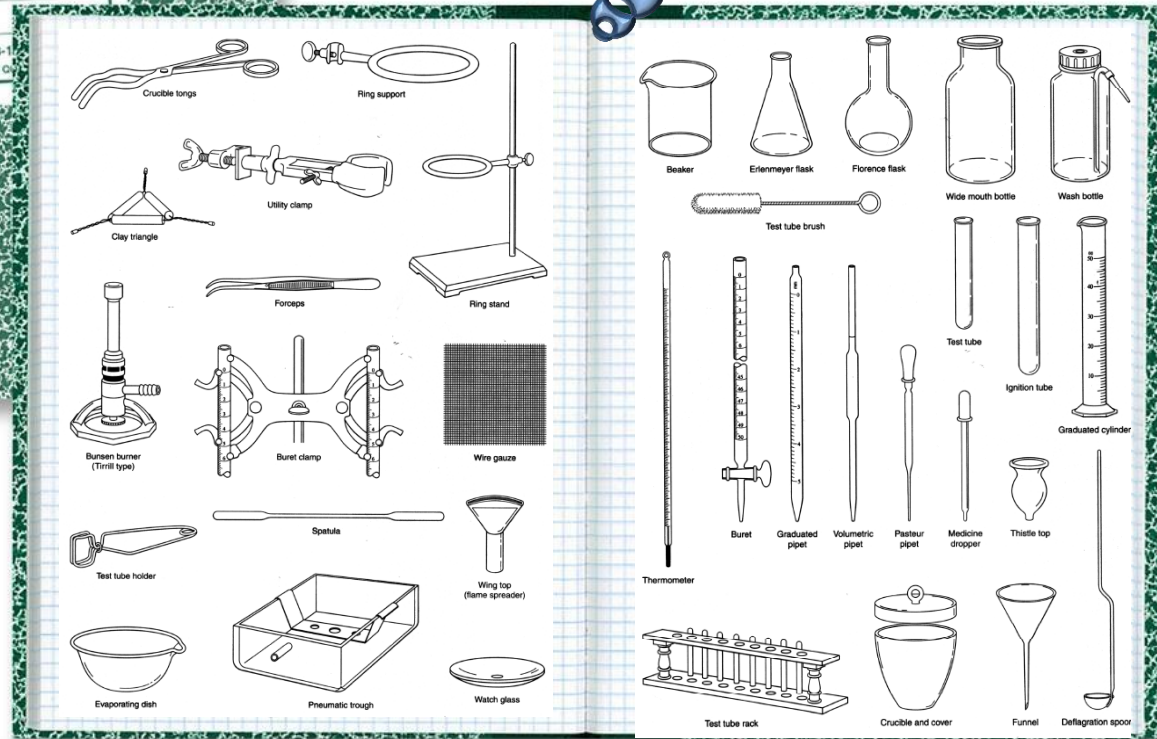

Tips to a Successful Lab

1st Organize your Lab Notebook.

2nd Read Labs before Class and Follow Procedures. Watch any Videos that relate to the Lab.

3rd Date every Experiment.

4th Memorize all tools used in Experiments

Finally remember that your exam's grade will reflect the work you put into the Lab Notebook

